

# Digital Still Camera

---

## Operating Instructions

Before operating the unit, please read this manual thoroughly, and retain it for future reference.

## Owner's Record

The model and serial numbers are located on the bottom. Record the serial number in the space provided below. Refer to these numbers whenever you call upon your Sony dealer regarding this product.

Model No. \_\_\_\_\_

Serial No. \_\_\_\_\_

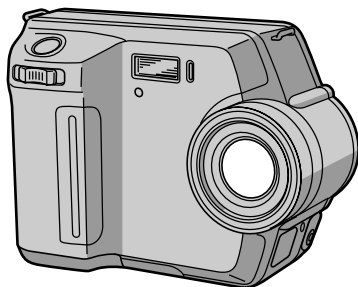

# FD Mavica



## MVC-FD100/FD200

## WARNING

To prevent fire or shock hazard, do not expose the unit to rain or moisture.

## For the Customers in the U.S.A.

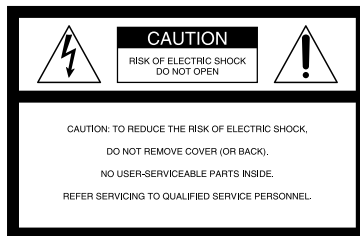

This symbol is intended to alert the user to the presence of uninsulated “dangerous voltage” within the product’s enclosure that may be of sufficient magnitude to constitute a risk of electric shock to persons.



This symbol is intended to alert the user to the presence of important operating and maintenance (servicing) instructions in the literature accompanying the appliance.

If you have any questions about this product, you may call:

Sony Customer Information Center  
1-800-222-SONY (7669)

The number below is for the FCC related matters only.

## Regulatory Information

### Declaration of Conformity

Trade Name: SONY  
Model No.: MVC-FD100  
Responsible Party: Sony Electronics Inc.  
Address: 16450 W. Bernardo Dr,  
San Diego, CA 92127  
U.S.A.  
Telephone Number: 858-942-2230

This device complies with Part 15 of the FCC Rules. Operation is subject to the following two conditions: (1) This device may not cause harmful interference, and (2) this device must accept any interference received, including interference that may cause undesired operation.

### Declaration of Conformity

Trade Name: SONY  
Model No.: MVC-FD200  
Responsible Party: Sony Electronics Inc.  
Address: 16450 W. Bernardo Dr,  
San Diego, CA 92127  
U.S.A.  
Telephone Number: 858-942-2230

This device complies with Part 15 of the FCC Rules. Operation is subject to the following two conditions: (1) This device may not cause harmful interference, and (2) this device must accept any interference received, including interference that may cause undesired operation.

### CAUTION

You are cautioned that any changes or modifications not expressly approved in this manual could void your authority to operate this equipment.

### Notes:

- This equipment has been tested and found to comply with the limits for a Class B digital device, pursuant to Part 15 of the FCC Rules. These limits are designed to provide reasonable protection against harmful interference in a residential installation. This equipment generates, uses, and can radiate radio frequency energy and, if not installed and used in accordance with the instructions, may cause harmful interference to radio

communications. However, there is no guarantee that interference will not occur in a particular installation. If this equipment does cause harmful interference to radio or television reception, which can be determined by turning the equipment off and on, the user is encouraged to try to correct the interference by one or more of the following measures:

- Reorient or relocate the receiving antenna.
- Increase the separation between the equipment and receiver.
- Connect the equipment into an outlet on a circuit different from that to which the receiver is connected.
- Consult the dealer or an experienced radio/TV technician for help.

The supplied interface cable must be used with the equipment in order to comply with the limits for a digital device pursuant to Subpart B of Part 15 of FCC Rules.

- This product contains mercury. Disposal of this product may be regulated if sold in the United States. For disposal or recycling information, please contact your local authorities or the Electronics Industries Alliance (<http://www.eiae.org>).

## For the Customers in the U.S.A. and Canada

### RECYCLING LITHIUM-ION BATTERIES

Lithium-Ion batteries are recyclable.

You can help preserve our environment by returning your used rechargeable batteries to the collection and recycling location nearest you.

For more information regarding recycling of rechargeable batteries, call toll free 1-800-822-8837, or visit <http://www.rbrcc.org/>.

**Caution:** Do not handle damaged or leaking Lithium-Ion batteries.



### CAUTION

TO PREVENT ELECTRIC SHOCK, DO NOT USE THIS POLARIZED AC PLUG WITH AN EXTENSION CORD, RECEPTACLE OR OTHER OUTLET UNLESS THE BLADES CAN BE FULLY INSERTED TO PREVENT BLADE EXPOSURE.

### NOTICE FOR THE CUSTOMERS IN THE UNITED KINGDOM

A moulded plug complying with BS 1363 is fitted to this equipment for your safety and convenience.

Should the fuse in the plug supplied need to be replaced, a 5 AMP fuse approved by ASTA or BSI to BS 1362, (i.e. marked with ⚡ or ⚡ mark) must be used.

If the plug supplied with this equipment has a detachable fuse cover, be sure to attach the fuse cover after you change the fuse. Never use the plug without the fuse cover. If you should lose the fuse cover, please contact your nearest Sony service station.

### For the Customers in Germany

Directive: EMC Directive 89/336/EEC.92/31/EEC

This equipment complies with the EMC regulations when used under the following circumstances:

- Residential area
- Business district
- Light-industry district

(This equipment complies with the EMC standard regulations EN55022 Class B.)

### Attention for the Customers in Europe

This product has been tested and found compliant with the limits sets out on the EMC Directive for using connection cables shorter than 3 meters (9.8 feet).

The electromagnetic fields at the specific frequencies may influence the picture of this camera.

## Be sure to read the following before using your camera

### Operating instructions

Before operating the unit, please read this manual thoroughly, and retain it for future reference.

As you read through this manual, buttons and settings on the camera are shown in capital letters.

e.g. Press DISPLAY.

### Trial recording

Before you record one-time events, you may want to make a trial recording to make sure that the camera is working correctly.

### No compensation for contents of the recording

The recorded images cannot be compensated if recording or playback cannot be performed due to a trouble of your camera or recording medium.

### Notes on image data compatibility of the “Memory Stick”

- This camera conforms with the Design rule for Camera File system universal standard established by the JEITA (Japan Electronics and Information Technology Industries Association). You cannot play back on your camera still images recorded on other equipment (DCR-TRV890E/TRV900/TRV900E, DSC-D700, DSC-D770) that does not conform with this universal standard. (These models are not sold in some areas.)
- Playback of images recorded with your camera on other equipment and playback of images recorded or edited with other equipment on your camera are not guaranteed.

### Precaution on copyright

Television programs, films, video tapes, and other materials may be copyrighted.

Unauthorized recording of such materials may be contrary to the provision of the copyright laws.

### Do not shake or strike the camera

In addition to malfunctions and inability to record images, this may render the floppy disks or the “Memory Stick”’s unusable or image data breakdown, damage or loss may occur.

### LCD screen, finder (only models with a finder) and lens

- The LCD screen and the finder are manufactured using extremely high-precision technology so over 99.99% of the pixels are operational for effective use. However, there may be some tiny black points and/or bright points (white, red, blue or green in color) that constantly appear on the LCD screen and the finder. These points are normal in the manufacturing process and do not affect the recording in any way.
- Be careful when placing the camera near a window or outdoors. Exposing the LCD screen, the finder or the lens to direct sunlight for long periods may cause malfunctions.

### Do not get the camera wet

When taking pictures outdoors in the rain or under similar conditions, be careful not to get the camera wet. If moisture condensation occurs, refer to page 83 and follow the instructions on how to remove it before using the camera.

### Back up recommendation

To avoid the potential risk of data loss, always copy (back up) data to a disk.

### When the camera is used for long periods

Note that the camera body may become hot.

# Introduction

## Check images after recording

Recording still images:

page 18

Playing back still images:

page 24

Deleting images (DELETE):

page 75

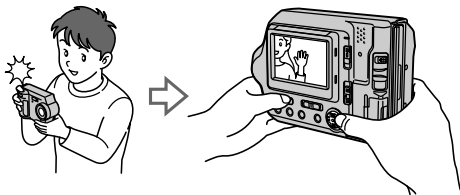

## Capture images with your computer

You can copy images onto your computer and view and modify images or attach images to e-mail on your computer using the supplied USB cable and application software.

Viewing images using a computer: page 27

Recording still images for e-mail (E-MAIL): page 61

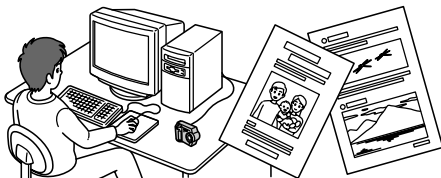

## Records a moving picture

The digital still camera can record a moving picture for maximum 60 seconds. Your camera does not record sound.

Recording moving images: page 23

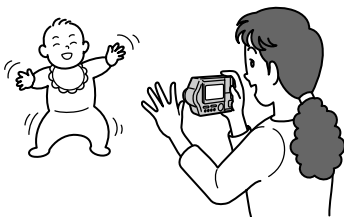

## Select from various recording modes

Creating Clip Motion Files: page 59

Recording text documents (TEXT): page 62

Recording still images as uncompressed files (TIFF): page 63

# Table of contents

Introduction .....	5
--------------------	---

## Getting started

Identifying the parts .....	7
Preparing the power supply .....	9
Setting the date and time .....	14
Inserting a floppy disk .....	16
Inserting a “Memory Stick” .....	17

## Basic operations

### ► Recording

Recording still images .....	18
Recording moving images .....	23

### ► Playback

Playing back still images .....	24
Playing back moving images .....	25
Viewing images using a computer .....	27
Image file storage destinations and image file names .....	38
Viewing images using “ImageMixer” .....	42

## Advanced operations

### Before performing advanced operations

How to use the PLAY/STILL/ MOVIE selector .....	48
How to use the control button .....	48
How to change the menu settings .....	50

### ► Various recording

Setting the image size (IMAGE SIZE) .....	57
Creating Clip Motion Files .....	59
Recording still images for e-mail (E-MAIL) .....	61
Recording text documents (TEXT) .....	62
Recording still images as uncompressed files (TIFF) .....	63
Recording images in macro .....	64
Setting the distance to the subject .....	64
Using the PROGRAM AE function .....	65

Adjusting the exposure (EXPOSURE) .....	67
Adjusting the white balance (WHITE BALANCE) .....	68
Recording the date and time on the still image (DATE/TIME) .....	69
Enjoying picture effects (PICTURE EFFECT) .....	69

### ► Various playback

Playing back six images at once (INDEX) .....	70
Enlarging a part of the still image (Zoom and trimming) .....	71
Playing back the still images in order (SLIDE SHOW) .....	72
Viewing images on a TV screen .....	73

### ► Editing

Preventing accidental erasure (PROTECT) .....	74
Deleting images (DELETE) .....	75
Changing the recorded still image size (RESIZE) .....	76
Copying images (COPY) .....	77
Copying all the information on your floppy disk (DISK COPY) .....	79
Selecting still images to print (PRINT MARK) .....	80
Format .....	81

### ► As an external drive

Using the camera as an external drive of a computer .....	82
--	----

## Additional information

Precautions .....	83
On “Memory Stick”s .....	85
Using your camera abroad .....	85
About “InfoLITHIUM” battery pack .....	86
Troubleshooting .....	88
Warning and notice messages .....	93
Self-diagnosis display .....	95
Specifications .....	96
LCD screen indicators .....	97
Index .....	99

# Identifying the parts

See the pages in parentheses for details of operation.

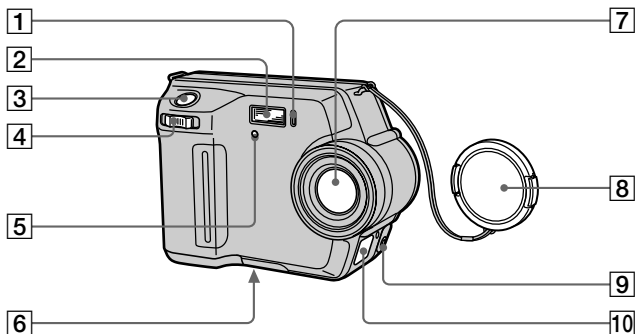

**1 Self-timer lamp (21)**

**2 Flash (22)**

**3 Shutter button (18, 23)**

**4 Zoom lever (20)**

**5 Photocell window for flash**

Do not block while recording.

**6 Tripod receptacle (bottom surface)**

Use a tripod with a screw length of less than 5.5 mm (7/32 inch). You cannot firmly secure the camera to tripods having longer screws, and may damage the camera.

**7 Lens**

**8 Lens cap (supplied)**

**9 VIDEO OUT jack (73)**

**10 DC IN cover/DC IN jack (10, 13)**

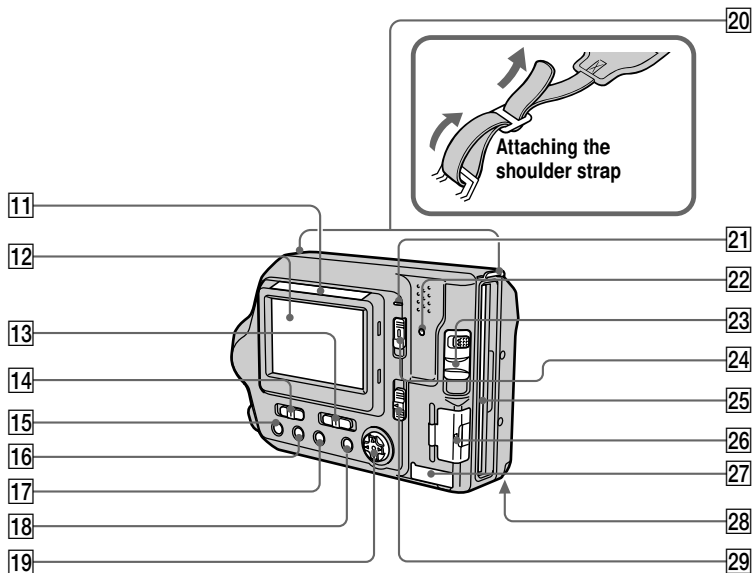

**11 Photocell window for LCD screen**

The LCD screen becomes brighter when exposed to sunlight.

**12 LCD screen**

**13 PLAY/STILL/MOVIE selector (48)**

**14 LCD BACKLIGHT switch (20)**

**15  $\frac{1}{2}$  (Flash) button/  
 $\frac{1}{2}$  (Flash) lamp (22)**

**16 FOCUS button (64)**

**17 PROGRAM AE button (65)**

**18 DISPLAY button (21)**

**19 Control button (48)**

**20 Hooks for strap**

**21 POWER ON/OFF (CHG) (Charge) lamp (10)**

**22 Access lamp (18, 19)**

**23 DISK EJECT lever (16)**

**24 POWER switch (14)**

**25 Floppy disk slot (16)**

**26 "Memory Stick" cover/  
"Memory Stick" slot (17)**

**27 USB cover/USB jack (29)**

**28 Battery cover (9)**

**29 MS /FD ("Memory Stick"/floppy disk) selector**

# Preparing the power supply

## Installing the battery pack

Your camera operates only with the NP-F330 (supplied)/F550 (optional) “InfoLITHIUM” battery pack\* (L series). See page 86 for more information about “InfoLITHIUM” battery pack.

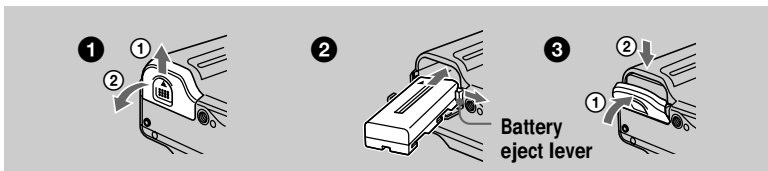

### 1 Open the battery cover.

Slide the battery cover in the direction of the arrow.

### 2 Install the battery pack.

Press and hold the battery eject lever and then insert the battery pack with the ▲ mark facing toward the battery compartment.

### 3 Close the battery cover.

## To remove the battery pack

Open the battery cover. Slide the battery eject lever rightward, and remove the battery pack.

Be careful not to drop the battery pack when removing it.

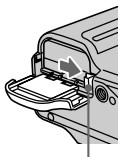

Battery eject lever

### \* What is “InfoLITHIUM”?

“InfoLITHIUM” is a lithium ion battery pack which can exchange information such as battery consumption with compatible video equipment. “InfoLITHIUM” L series battery packs have the  mark. “InfoLITHIUM” is a trademark of Sony Corporation.

## Charging the battery pack

When the camera is turned on, you cannot charge the battery pack. Be sure to turn off the power of the camera.

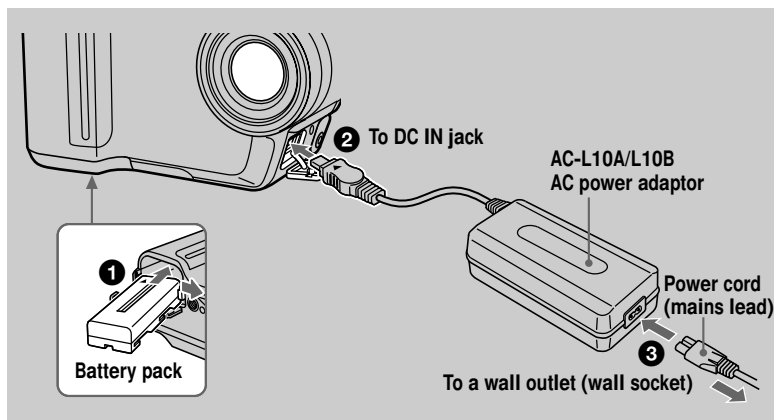

- 1** Insert the battery pack into your camera.
- 2** Open the DC IN cover and connect the AC power adaptor to the DC IN jack of your camera with the ▲ mark facing up.
- 3** Connect the power cord (mains lead) to the AC power adaptor and then to a wall outlet (wall socket).  
The POWER ON/OFF (CHG) lamp (orange) on the right of the LCD screen lights up when charging begins. When the POWER ON/OFF (CHG) lamp goes off, **full charge** is completed.

## After charging the battery pack

Disconnect the AC power adaptor from the DC IN jack on your camera.

## Battery remaining indicator

The LCD screen on the camera shows the remaining time for which you can still record or play back images.

This indication may not be entirely accurate depending on the conditions of use and the operating environment.

We recommend charging the battery pack in an ambient temperature of between 10°C to 30°C (50°F to 86°F).

## NP-F330 (supplied)/F550 (optional) battery pack

When you record images in an extremely cold location or using the LCD screen, the operating time becomes short. When using the camera in an extremely cold location, place the battery pack in your pocket or other place to keep it warm, then insert the battery pack into the camera just before recording. When using a pocket heater, take care not to let the heater directly contact the battery.

### Auto power-off function

If you do not operate the camera for about three minutes when using a battery pack, the camera turns off automatically to prevent wearing down the battery pack. To use the camera again, slide the POWER switch down to turn on the camera again.

### Note on the POWER ON/OFF (CHG) lamp during charging

The POWER ON/OFF (CHG) lamp may flash:

- When a malfunction occurs in the battery pack.

The POWER ON/OFF (CHG) lamp does not light up:

- When the battery pack is not installed properly.

### Charging time

Battery pack	Full charge (min.)
NP-F330 (supplied)	Approx. 150
NP-F550	Approx. 210

This represents the time required to charge a completely discharged battery pack using the supplied AC-L10/L10B AC power adaptor in an environment where the ambient temperature is 25°C (77°F).

### The number of images that can be recorded/played back and battery life

The tables show approximate guidelines for the length of time the camera can be used when you record in Normal mode with the LCD BACKLIGHT switch ON in an environment where the ambient temperature is 25°C (77°F), and the battery pack is fully charged. The guidelines for the number of images that can be recorded or played back shown below allow for changing a floppy disk or “Memory Stick” as necessary. Please note that the numbers and time shown in the following table, “Recording still images under average conditions,” are only for recording with a “Memory Stick.” Actual results may differ slightly from these, depending on the conditions of use.

## Recording still images

Under average conditions\*1)

Image size	NP-F330 (supplied)		NP-F550 (optional)	
	Number of images	Battery life (min.)	Number of images	Battery life (min.)
1600×1200 (MVC-FD200)	Approx. 150	Approx. 75	Approx. 340	Approx. 170
1280×960 (MVC-FD100)	Approx. 150	Approx. 75	Approx. 340	Approx. 170

\*1) Recording under the following conditions:

- Recording one image every 30 seconds.
- Alternatively sliding the zoom lever to the W and T sides fully for each recording.
- Using the flash once in every two recordings.
- Turning the camera on and off once in every 10 recordings.

Recording continuously\*2)

Storage media	NP-F330 (supplied)		NP-F550 (optional)	
	Number of images	Battery life (min.)	Number of images	Battery life (min.)
Floppy disk	Approx. 750	Approx. 70	Approx. 1600	Approx. 150
“Memory Stick”	Approx. 1600	Approx. 80	Approx. 3400	Approx. 170

\*2) Recording under the following conditions:

- The image size is set to 640×480.
- Flash mode is set to  (No flash).
- Recording every five seconds when using floppy disks and every three seconds when using a “Memory Stick.”

Playing back\*3) still images

Storage media	NP-F330 (supplied)		NP-F550 (optional)	
	Number of images	Battery life (min.)	Number of images	Battery life (min.)
Floppy disk	Approx. 2200	Approx. 80	Approx. 4800	Approx. 170
“Memory Stick”	Approx. 3000	Approx. 100	Approx. 6900	Approx. 230

\*3) Playing back single images in order, one approximately every two seconds

## Recording moving images

Recording continuously (when the image size is set to 160 112)

Storage media	Battery life (min.)	
	NP-F330 (supplied)	NP-F550 (optional)
Floppy disk	Approx. 85	Approx. 180
“Memory Stick”	Approx. 90	Approx. 190

**Note**

The battery life and number of images will be decreased when using at low temperature, using the flash, turning the power on/off frequently, or using the zoom.

## Using the AC power adaptor

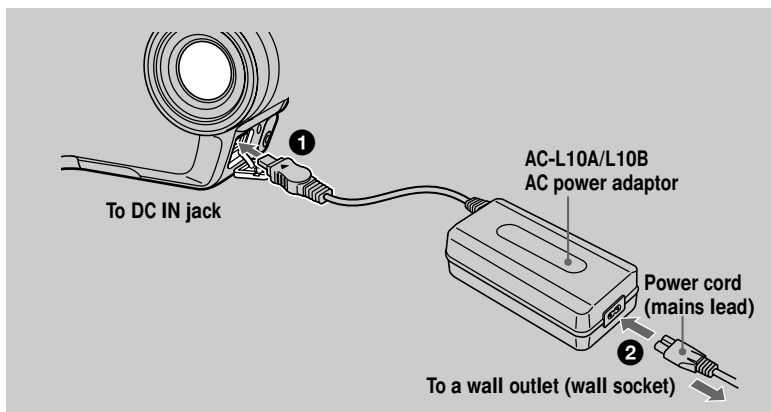

- 1** Open the DC IN cover and connect the AC power adaptor to the DC IN jack of your camera with the ▲ mark facing up.
- 2** Connect the power cord (mains lead) to the AC power adaptor and then to a wall outlet (wall socket).

## Using your camera abroad

For details, see page 85.

## When using the AC power adaptor

Be sure to use it near a wall outlet (wall socket). If a malfunction occurs, disconnect the plug from the wall outlet (wall socket).

**Note**

Do not short the DC plug of the AC power adaptor with a metallic object, as this may cause a malfunction.

# Setting the date and time

When you first use your camera, set the date and time. If these are not set, the CLOCK SET screen appears whenever you turn on your camera.

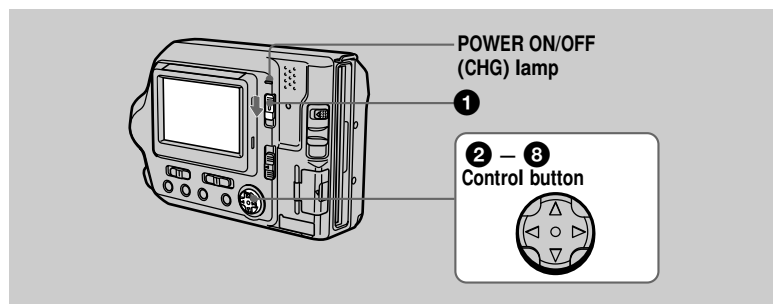

- 1 Press and hold the green button and slide the POWER switch in the direction of the arrow to turn on power.**  
The POWER ON/OFF (CHG) (green) lamp lights up.

- 2 Press  $\blacktriangle$  on the control button.**  
The menu bar appears on the LCD screen.

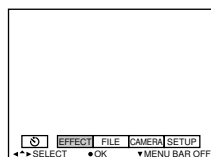

- 3 Select [SETUP] with  $\blacktriangleright$  on the control button, then press the center  $\bullet$ .**

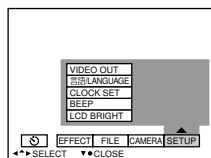

- 4 Select [CLOCK SET] with  $\blacktriangle/\blacktriangledown$  on the control button, then press the center  $\bullet$ .**

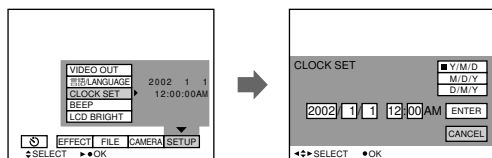

- 5** Select the desired date display format with ▲/▼ on the control button, then press the center ●.

Select from [Y/M/D] (year/month/day), [M/D/Y] (month/day/year), or [D/M/Y] (day/month/year).

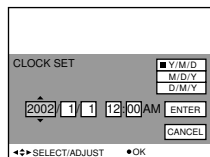

- 6** Select the year, month, day, hour or minute item you want to set with ◀/▶ on the control button.

The item to be set is indicated with ▲/▼.

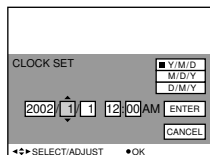

- 7** Set the numeric value with ▲/▼ on the control button, then press the center ● to enter it.

After entering the number, ▲/▼ moves to the next item. If you selected [D/M/Y] in step 5, set the time on a 24-hour cycle.

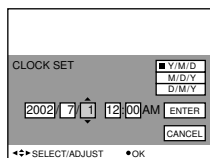

- 8** Select [ENTER] with ▶ on the control button, then press the center ● at the desired moment to begin clock movement.

The date and time are entered.

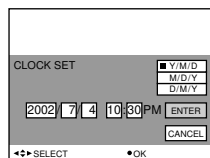

### To cancel the date and time setting

Select [CANCEL] with ▲/▼/◀/▶ on the control button, then press the center ●.

# Inserting a floppy disk

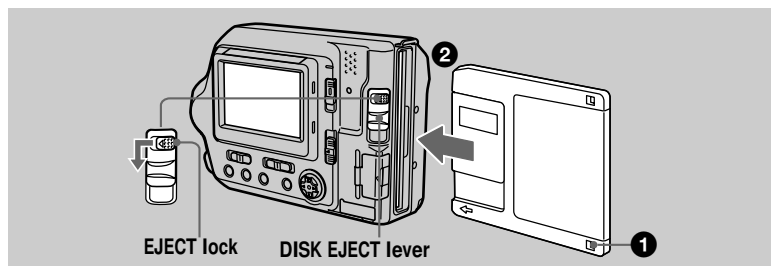

- 1 Check that the write protect tab is set to the recordable position for recording.

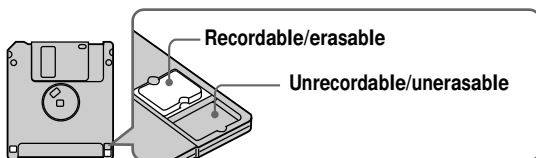

- 2 Insert the floppy disk until it clicks.

## Usable floppy disks

- Size: 3.5-inch
- Type: 2HD (1.44 MB)
- Format: MS-DOS format (512 bytes 18 sectors)

## Notes

- Do not insert the media other than the floppy disks described above.
- You cannot use the optional MSAC-FD2M/FD2MA Floppy Disk Adaptor for Memory Stick.
- If the access lamp is lit, data is being read or written. Never remove the floppy disk, turn off the power, or change the setting of the MS/FD selector while the access lamp is lit. Otherwise, the image data could be damaged or lost.

## Removing the floppy disk

While sliding the EJECT lock to the left, slide down the DISK EJECT lever.

# Inserting a "Memory Stick"

See page 85 for details about "Memory Stick".

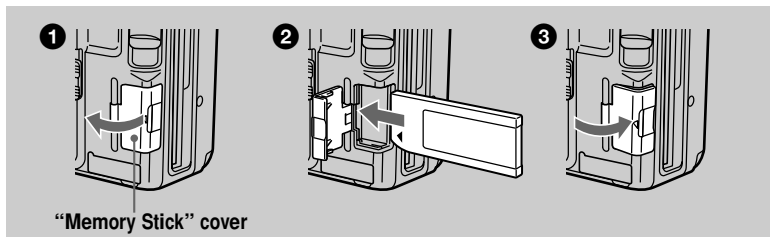

**1** Open the "Memory Stick" cover.

**2** Insert the "Memory Stick."

Insert the "Memory Stick" with the ► mark facing toward the "Memory Stick" slot as illustrated until it clicks.

**3** Close the "Memory Stick" cover.

## Removing the "Memory Stick"

Open the "Memory Stick" cover, then push the "Memory Stick" once lightly.

### Notes

- Insert the "Memory Stick" firmly until it clicks, otherwise a message such as "MEMORY STICK ERROR" will be displayed.
- If the access lamp is lit, data is being read or written. Never remove the "Memory Stick," turn off the power, or change the setting of the MS/FD selector while the access lamp is lit. Otherwise, the image data could be damaged or lost.
- You cannot record or edit images on a "Memory Stick" if the write-protect switch is set to the LOCK position.

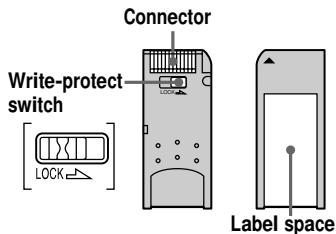

The position and shape of the write-protect switch may differ depending on the types of "Memory Stick" used.

## Recording still images

Still images are recorded in JPEG format.

Slide the POWER switch down to turn on the power and insert a floppy disk or a “Memory Stick” in your camera.

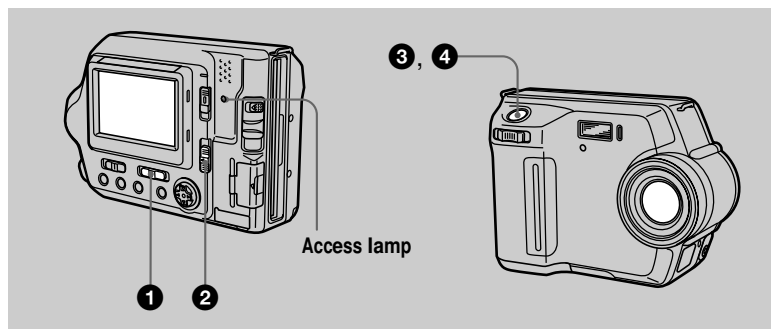

**1** Set the PLAY/STILL/MOVIE selector to STILL.

**2** Select the recording media using the MS/FD selector.

**MS:** When recording on the “Memory Stick.”

**FD:** When recording on the floppy disk.

**3** Press and hold the shutter button halfway down.

The image has not been recorded yet at this time. The camera automatically adjusts the exposure and focus in accordance with the subject and recording conditions. When the camera finishes the automatic adjustments, the AE/AF lock indicator ● stops flashing, then lights up and is followed by beeps, and the camera is ready for recording.

If you release the shutter button, the recording will be canceled.

AE/AF lock indicator (green)  
flashes → lights up

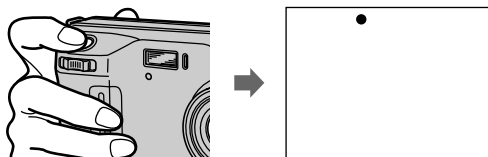

#### 4 Press the shutter button fully down.

The shutter clicks. “RECORDING” appears on the LCD screen, and the image will be recorded on the floppy disk or the “Memory Stick.” When “RECORDING” disappears from the LCD screen, you can start the next recording.

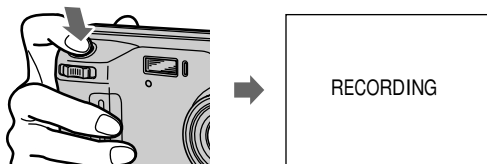

### For the number of images you can record on a floppy disk or a “Memory Stick”

See page 58.



#### Notes

- When recording bright subjects, the color of the LCD screen may change after the AE/AF is locked. However, this will not affect the recorded image.
- While the image is being recorded on a floppy disk or a “Memory Stick,” the access lamp lights. When this lamp is lit, do not shake or strike the camera. Also, do not turn the power off, not change the position of the MS/FD selector, or not remove the battery pack/floppy disk/“Memory Stick.” Otherwise, an image data breakdown may occur and the floppy disk or the “Memory Stick” may become unusable.
- When you press the shutter button fully down at once, the camera starts recording after the automatic adjustment is complete. However, the recording cannot be carried out if the flash is required for the recording and the  lamp (page 8) is flashing.





### Checking the last recorded image (Quick Review)

You can check the last recorded image by clearing the menu bar from the screen (page 49) and pressing  on the control button.

#### To return to the normal recording mode

Press the shutter button lightly, or select [RETURN] with  on the control button and then press the center .

#### To delete the image

- 1 Select [DELETE] in the Quick Review screen using  on the control button and press the center .
- 2 Select [OK] using  on the control button and press the center .

## Adjusting the brightness of the LCD screen

Adjust the brightness with the [LCD BRIGHT] item in the menu settings (page 56). This adjustment does not affect the brightness of the images recorded on the floppy disk or the "Memory Stick."

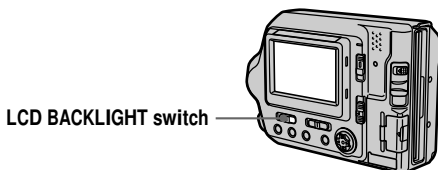

### To turn off the LCD backlight

Set the LCD BACKLIGHT switch to OFF to save the battery.

## Using the zoom feature

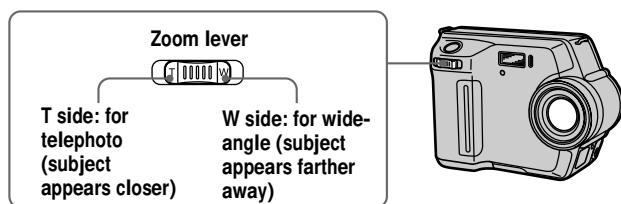

### If you cannot get a sharp focus on a close subject

Slide the zoom lever to the W side and move closer to the subject until the focus is sharp (page 64).

### Minimum focal distance to the subject

W side: About 25 cm (9 7/8 inches)

T side: About 80 cm (31 1/2 inches)

To record even closer subjects, see page 64.

## Digital zoom function

This camera has a digital zoom function.

Digital zoom enlarges the image by digital processing, and it starts to function when the zoom exceeds 3 .

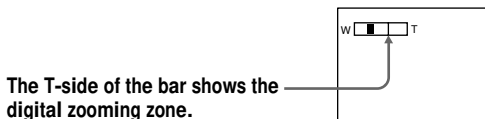

## Using digital zoom

- The maximum zoom magnification is 6 .
- Digital zooming deteriorates the picture quality. When digital zoom is not necessary, set [DIGITAL ZOOM] to [OFF] in the menu settings (page 54).

### Note

Digital zoom does not work for moving images.

## The indicators on the LCD screen during recording

Press DISPLAY to turn on/off the indicators on the LCD screen. See page 97 for a detailed description of the indicators.

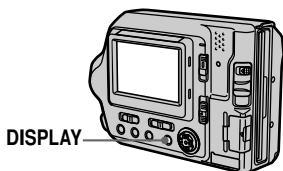

### Notes

- You cannot turn off the  (self-timer) indicator and some of the indicators used in advanced operations.
- The indicators on the LCD screen are not recorded.

## Using the self-timer

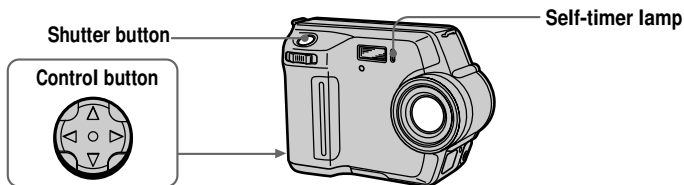

When you use the self-timer function, the subject is recorded approximately 10 seconds after you press the shutter button.



Select  on the LCD screen using /▶/▲/▼ on the control button and press the center .

The  (self-timer) indicator appears on the LCD screen, and the subject is recorded approximately 10 seconds after you press the shutter button. The self-timer lamp flashes until the subject is recorded.

### To cancel the self-timer



To cancel the self-timer, press ▲ on the control button to display the menu bar and select  and press the center  on the control button to clear  on the LCD screen.

## Recording images with the flash

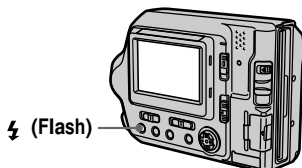
The initial setting is AUTO (no indication). In this mode, the flash is automatically activated when the surroundings are dark. To change the flash mode to other than AUTO, press  (Flash) several times until the desired flash mode indicator appears on the LCD screen.



Each time you press the button, the indicator changes as follows.

(No indication) →  →  →  → (No indication)

 Auto red-eye reduction : The flash strobesc before recording to reduce the red-eye phenomenon.

 Forced flash : The flash strobesc regardless of the surrounding brightness.

 No flash : The flash does not strobesc.

You can change the amount of the flash light with [FLASH LEVEL] in the menu settings (page 54).

### Notes

- The recommended shooting distance of the built-in flash is 0.5 to 2.0 m (1 2/3 to 6 2/3 feet) when [ISO] in the menu is [AUTO].
- Attaching a conversion lens (optional) may block the light from the flash and the shadow of the lens may be recorded.
- Auto red-eye reduction may not produce the desired red-eye reduction effects depending on individual differences, the distance to the subject, if the subject does not see the pre-strobe, or other conditions.
- The flash effect is not obtained easily when you use forced flash in a bright location.

# Recording moving images

Moving images are recorded in MPEG format. Your camera does not record sound. Slide the POWER switch down to turn on the power and insert a floppy disk or a “Memory Stick” in your camera.

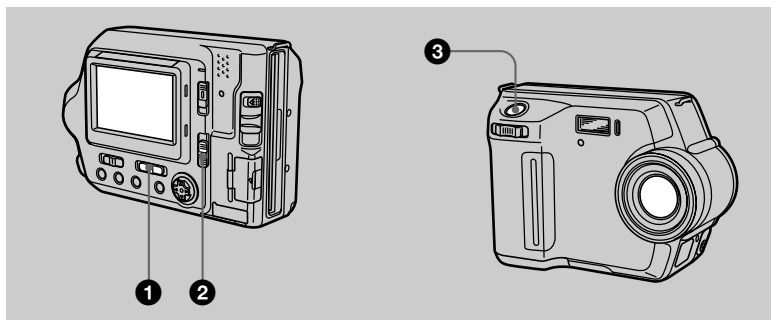

**1 Set the PLAY/STILL/MOVIE selector to MOVIE.**

**2 Select the recording media using the MS/FD selector.**

**MS:** When recording on the “Memory Stick.”

**FD:** When recording on the floppy disk.

**3 Press the shutter button fully down.**

“REC” appears on the LCD screen, and the moving image is recorded on the floppy disk or the “Memory Stick.”

**If you press the shutter button momentarily**

The image is recorded for 5 seconds. The recording time can be set to 10 or 15 seconds with [REC TIME SET] in the menu settings (page 53).

**If you hold the shutter button down**

The image is recorded while the shutter button is held down for up to 60 seconds. However, when [IMAGE SIZE] in the menu settings is set to [320×240], the maximum recording time is 15 seconds (page 57).

## Adjusting the brightness of the LCD screen, zooming or using the self-timer

See pages 20 to 22.

## LCD screen indicators during recording

Press DISPLAY to turn on/off the indicators on the LCD screen.

These indicators are not recorded. See page 97 for a detailed description of the indicators.

# Playing back still images

Slide the POWER switch down to turn on the power and insert a floppy disk or a “Memory Stick” in your camera.

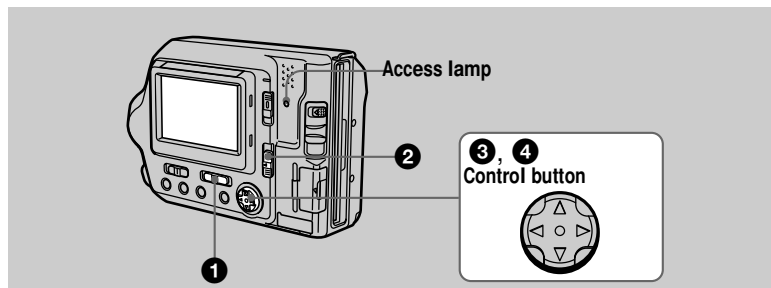

- 1** Set the **PLAY/STILL/MOVIE** selector to **PLAY**.  
The last recorded image (still or moving) appears on the LCD screen.
- 2** Select the playback media using the **MS/FD** selector.  
**MS**: When playing back images in the “Memory Stick.”  
**FD**: When playing back images in the floppy disk.
- 3** Press **▲** on the control button to display the menu bar on the LCD screen.
- 4** Select the desired still image with the control button.  
Press **▲/▼/◀/▶** on the control button to select **◀/▶** on the LCD screen, then press **◀/▶**.  
**◀**: To display the preceding image.  
**▶**: To display the next image.

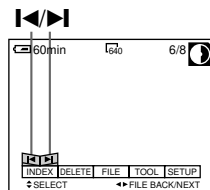

## When the menu bar is not displayed

You can directly select and play back the image with **◀/▶** on the control button.

### Notes

- You might not be able to correctly play back images recorded with this camera on other equipment.
- You may not be able to play back images whose image sizes are larger than the maximum image size that can be used with this camera for recording.

## LCD screen indicators during still image playback

Press **DISPLAY** to turn on/off the indicators on the LCD screen.  
See page 98 for a detailed description of the indicators.

# Playing back moving images

Slide the POWER switch down to turn on the power and insert a floppy disk or a "Memory Stick" in your camera.

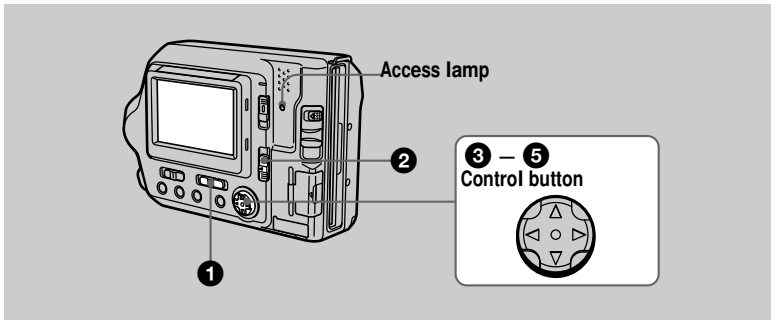

- 1 Set the PLAY/STILL/MOVIE selector to PLAY.**  
The last recorded image (still or moving) appears on the LCD screen.
- 2 Select the playback media using the MS/FD selector.**  
**MS:** When playing back images in the "Memory Stick."  
**FD:** When playing back images in the floppy disk.
- 3 Press ▲ on the control button to display the menu bar on the LCD screen.**

- 4 Select the desired moving image with the control button.**

Moving images are displayed one size smaller than still images.

Press ▲/▼/◀/▶ on the control button to select

◀/▶ on the LCD screen, then press ◀/▶.

◀: To display the preceding image.

▶: To display the next image.

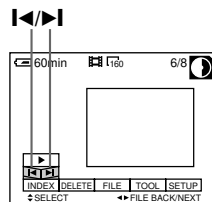

- 5** Select the ► (playback) button on the LCD screen with ▲/▼/◀/▶ on the control button, then press the center ●.

The moving image is played back.

During playback, ► (playback) changes to || (pause).

► (playback)/  
|| (pause) button

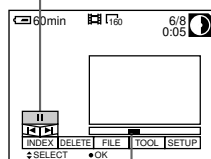

Playback bar

### To pause playback

Select || (pause) on the LCD screen with ▲/▼/◀/▶ on the control button, then press the center ●.

### When the menu bar is not displayed

You can directly select the image with ◀/▶ on the control button, and play back the image by pressing the center ●. When you press the center ● during playback, playback is paused.

### LCD screen indicators during moving image playback

Press DISPLAY to turn on/off the indicators on the LCD screen.  
See page 98 for a detailed description of the indicators.

# Viewing images using a computer

You can view or edit image data recorded with your camera using software installed in your computer. You can also attach the image data to e-mail.



## Viewing images using a floppy disk drive

**Example: For Windows Me users**

---

**1 Turn on your computer and insert a floppy disk in the floppy disk drive of your computer.**

---

**2 Open “ My Computer” and double-click “ 3 1/2 Floppy (A:).”**

---

**3 Double-click a file to be viewed.**

See “Image file storage destinations and image file names” (page 38) for details.

It is recommended that you copy a moving image file to the hard disk of your computer before viewing it. If you view the file directly from a floppy disk, the image may break off.

---

## Viewing images on a computer using the USB cable

This section describes the method for viewing images on a computer using the supplied USB cable.

**The USB cable** is used to connect the camera to a computer so that operations can be performed on image files recorded in a floppy disk or a “Memory Stick” from the computer.

**In order to use the USB cable**, a USB driver must be installed in the computer beforehand.

Be sure to also refer to the operation manuals for your computer and the application software.

**Viewing images on Windows: page 28**

**Viewing images on Macintosh: page 34**

**Notes on using your computer: page 37**

### Notes

- Data recorded with your camera is stored in the following formats. Make sure that applications that support these file formats are installed on your computer.
  - Still images (other than TEXT mode, uncompressed mode, and Clip Motion): JPEG format
  - Moving images: MPEG format
  - Uncompressed mode still images: TIFF format
  - TEXT mode/Clip Motion: GIF format
- Depending on your application software, the file size may increase when you open a still image file.

- When you copy an image to the camera from your computer, which was modified with retouching software and was converted to another file format, the “FILE ERROR” message may appear and you may be unable to open the image.
- Depending on your application software, only the first frame of the Clip Motion file may be played back.

## Communications with your computer (for Windows only)

Communications between your camera and your computer may not recover after recovering from Suspend or Sleep.

- 
- Microsoft, Windows and Windows Media are either registered trademarks or trademarks of Microsoft Corporation in the United States and/or other countries.
  - Macintosh, Mac OS and QuickTime are either registered trademarks or trademarks of Apple Computer, Inc.
  - All other product names mentioned herein may be the trademarks or registered trademarks of their respective companies. Furthermore, “™” and “®” are not mentioned in each case in this manual.
  - In this manual, the Windows 2000 Professional is referred to as “Windows 2000”, and Windows Millennium Edition is referred to as “Windows Me”, and Windows XP Home Edition and Windows XP Professional are referred to as “Windows XP.”

## Viewing images on Windows

### Recommended computer environment

OS: Microsoft Windows 98, Windows 98SE, Windows 2000 Professional, Windows Millennium Edition, Windows XP Home Edition, Windows XP Professional

The above OS must be installed at the factory.

Operation is not assured in an environment upgraded to the operating systems described above.

CPU: MMX Pentium 200 MHz or faster

Display: Resolution of 800×600 dots or higher, High Color (16-bit color, 65 000 colors) or more

The USB connector must be provided as standard.

Windows Media Player (recommended) must be installed to play back moving pictures.

### Notes

- If you connect two or more devices that use USB to a single computer or use a hub, operation is not guaranteed.
- Some USB devices may not operate if they are connected to the computer at the same time as your camera.
- Operations are not guaranteed for all the recommended computer environments mentioned above.

## General procedure for viewing images

### Step 1 Installing the USB driver to the computer (page 29)

Perform this step only when you view images on your computer for the first time.

### Step 2 Connecting your camera to your computer using the USB cable (page 30)

### Step 3 Viewing images on Windows (page 32)

#### For Windows XP users

You do not have to install a USB driver. Windows XP recognizes the camera as a drive as soon as it is connected to the computer using the USB cable. Begin the procedure from **Step 2**.

The operation below is explained using Windows Me. The window screen and operation method may be different depending on the type of OS.

### Step 1 Installing the USB driver to the computer

Before connecting your camera to your computer, install the USB driver to the computer. The USB driver is included with the application software in the CD-ROM which is supplied with your camera.

#### **For Windows 98, Windows 98SE, Windows 2000, and Windows Me users**

**Do not connect your camera to your computer yet. Be sure to complete installation of the USB driver before connecting your camera to the computer. If you connect the USB cable first, you will be unable to install the USB driver properly.**

See “If the Removable Disk does not appear” (page 33) for corrective measures if the USB cable was connected before installing the driver and the driver software could not be installed correctly.

## Before operation

If you are using Windows 2000, log in as an administrator and then install the USB driver.

---

### 1 Turn on your computer and allow Windows to load.

Close all applications you are running on your computer.

---

### 2 Insert the supplied CD-ROM in the CD-ROM drive of your computer.

The title screen appears after a moment.



#### If the title screen does not appear

① Double-click "My Computer" on the Desktop.

② Double-click the CD-ROM ("ImageMixer (E:)\*").

\* The drive symbol ((E:), etc.) may differ depending on your computer.

#### Note

Set the display to 800×600 dots or higher and High Color (16-bit color, 65 000 colors) or more. If it is set to less than 800×600 dots and 256 colors, the installation window does not appear.

---

### 3 Click "USB Driver" on the screen.

The "Welcome to the InstallShield Wizard for Sony USB Driver" window appears.

---

### 4 Follow the on-screen messages to install the USB driver.

---

### 5 Eject the CD-ROM from the computer.

---

### 6 Select "Yes, I want to restart my computer now" and click "Finish."

Your computer restarts and you can connect your camera to your computer.

---

## Step 2 Connecting your camera to your computer using the USB cable

You can connect your camera to your computer after Windows is loaded.

---

### 1 Insert a floppy disk or a "Memory Stick" in your computer and set the MS/FD selector in accordance with the media you have inserted.

- 2 Connect the AC power adaptor to your camera and turn on your camera.
- 3 Use the supplied dedicated USB cable to connect the USB jack (mini-B) on your camera to the USB connector on your computer.

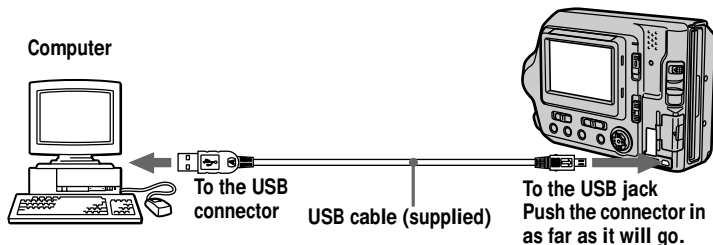

"USB MODE" appears on the LCD screen of your camera.

When you connect the camera for the first time, the operation automatically starts to allow your computer to recognize the camera. Be sure to wait until the operation finishes.

See "If the Copy Wizard appears" (page 33) if you are using Windows XP.

#### **Cautions**

- If you connect your camera to a computer with two or more USB jacks, do not connect any other USB device excepting a keyboard and/or mouse.
- If you have a desktop computer, use the USB jack on the rear panel of the computer.

**When you disconnect the USB cable from your computer, when you remove a floppy disk or a "Memory Stick" from the camera being connected to the computer using the USB cable, and when you switch the MS/FD selector**

For Windows 2000, Windows Me, and Windows XP users

- 1 Double-click the "Remove hardware" icon displayed at the lower right of the desktop screen.
- 2 Click "Sony DSC" and click "Stop."
- 3 Confirm the drive to be removed and click "OK."
- 4 Click "OK."
- 5 Perform operations such as disconnecting the USB cable.

For Windows 98 and Windows 98SE users

Perform only step 5 above.

## Step 3 Viewing images on Windows

You can view the images recorded in your camera while the camera is connected to your computer.

### ❶ Open “My Computer” on Windows and double-click the newly recognized drive “Removable Disk” (E:)\*.

The folder in a floppy disk or a “Memory Stick” is displayed.

If “Removable Disk” is not displayed, see “If the Removable Disk does not appear” (page 33).

\* The drive symbol ((E:), etc.) may differ depending on your computer.

### ❷ Select an image file to be viewed from the folder and double-click the file.

See “Image file storage destinations and image file names” (page 38) for further information.

#### Viewing an image of a floppy disk

Desired file type	Double-click in this order
E-mail image	“E-mail” folder → Image file
Other files	Image file

#### Viewing an image of a “Memory Stick”

Desired file type	Double-click in this order
Still image	“Dcim” folder → “100msdcf” folder → Image file
Moving image*	“Mssony” folder → “Moml0001” folder → Image file*
Clip Motion image	“Dcim” folder → “100msdcf” folder → Image file
E-mail image TIFF image (uncompressed)	“Mssony” folder → “Imcif100” folder → Image file

\* Copying a file to the hard disk of your computer before viewing it is recommended. If you view the file directly from a floppy disk or a “Memory Stick,” the image may break off.

## To copy the image data to your computer

Open a folder that contains the image data to be copied, and drag and drop the image data to the “My Documents” (example) folder.

### Caution

If you copy an image with the same filename to the same folder in your computer, a confirmation message for overwriting the original image data will appear. If you want to delete the original image and copy an image you want to drag and drop, click “Yes.” If you want to keep the original image, click “No” and change the filename of the image you want to drag and drop.

## If the Copy Wizard appears (for Windows XP users)

Use the following procedure to copy an image data from your camera to your computer.

- 1 Click “Copy pictures to a folder on my computer using Microsoft Scanner and Camera Wizard,” and then click “OK.”
- 2 Follow the instructions displayed on the screen to copy an image.  
Select “My Documents” (example) as the copy destination.  
To copy another image, click “Finish”, disconnect the USB cable, and connect it again. Then, repeat the procedure in the Copy Wizard screen.

## If the Removable Disk does not appear

Delete a driver registered unintentionally while your camera is connected to your computer. See “Step 2 Connecting your camera to your computer using the USB cable (page 30)” for the connecting method. Perform all steps below to install the USB driver properly.

- 1 Open “Device Manager” on your computer.

### For Windows 2000 users:

Select “My Computer” → “Control Panel” → “System” open “Hardware” tab, and then click “Device Manager.”

### For Windows 98, Windows 98SE, Windows Me users:

Select “My Computer” → “Control Panel” → “System” and click “Device Manager.”

- 2 Check whether a USB driver is already installed.

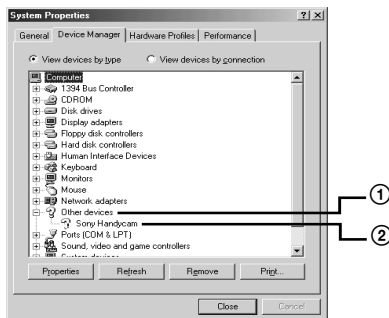

- ① Click “Other Devices.”
- ② Check for “ Sony DSC” or “ Sony Handycam” with a question mark.

### **3 If there is a device indicated with a question mark, delete it.**

- ① Click “ Sony DSC” or “ Sony Handycam”.
- ② Click “Remove.” The “Confirm Device Removal” screen appears.
- ③ Click the “OK” button.

### **4 Turn off your camera and disconnect the dedicated USB cable from the camera and computer.**

### **5 Install the USB driver provided on the supplied CD-ROM.**

See “Step 1 Installing the USB driver to the computer (page 29).”

## **Viewing images on Macintosh**

### **Recommended Computer environment**

OS: Mac OS 8.5.1/8.6/9.0/9.1/9.2, Mac OS X(v10.0/v10.1)

The above OS must be installed at the factory.

However, note that the upgrade to Mac OS 9.0/9.1 should be used for the following models.

— iMac with the Mac OS 8.6 factory pre-installed and a slot loading type CD-ROM drive

— iBook or Power Mac G4 with the Mac OS 8.6 factory pre-installed  
Mac OS X(v10.0/v10.1) users can use a USB connection only when a “Memory Stick” is used.

Display: Resolution of 800 600 dots or higher, 32 000-color mode or higher

The USB connector must be provided as standard.

QuickTime 3.0 or newer must be installed to play back moving pictures.

### **Notes**

- If you connect two or more devices that use USB to a single computer or use a hub, operation is not guaranteed.
- Some USB devices may not operate if they are connected to the computer at the same time as your camera.
- Operations are not guaranteed for all the recommended computer environments mentioned above.

### **General procedure for viewing images**

#### **Step 1 Installing the USB driver to the computer (page 35)**

Perform this step only when you view the images on your computer for the first time.

#### **Step 2 Connecting your camera to your computer using the USB cable (page 36)**

#### **Step 3 Viewing images on Macintosh (page 36)**

## For Mac OS 9.1/9.2 Mac OS X(v10.0/v10.1) users

You do not have to install a USB driver. Macintosh recognizes the camera as a drive as soon as it is connected to the Macintosh using the USB cable. Begin the procedure from **Step 2**.

### Step 1 Installing the USB driver to the computer

Before connecting your camera to your computer, install the USB driver to the computer. The USB driver is included with the application software in the CD-ROM which is supplied with your camera.

Set the display to 800×600 dots or higher and 32 000-color mode or higher.

- 1 Turn on your computer and allow the Mac OS to load.**
- 2 Insert the supplied CD-ROM in the CD-ROM drive of your computer.**  
The CD-ROM window (Pixela ImageMixer) appears.
- 3 Double-click the “Set up Menu” icon in the CD-ROM window.**  
The “PIXELA ImageMixer for Sony” appears.



- 4 Click “USB Driver” button (folder button).**  
The folder containing the six Sony USB driver related files opens.
- 5 Select the following two files and drag and drop them to the system folder. When the message is displayed, click “OK.”**
  - Sony USB Driver
  - Sony USB Shim
- 6 Restart your computer.**

## Step 2 Connecting your camera to your computer using the USB cable

See page 30 for the procedure to connect your camera to your computer using the USB cable.

**When you disconnect the USB cable from your computer, when you remove a floppy disk or a “Memory Stick” from the camera being connected to the computer using the USB cable, and when you switch the MS/FD selector**

Drag and drop the floppy disk or the “Memory Stick” icon into the recycle bin and then perform operations such as disconnecting the USB cable.

### For Mac OS X(v10.0) users

Turn off your computer first and then perform operations such as disconnecting the USB cable.

## Step 3 Viewing images on Macintosh

You can view the images recorded in your camera while the camera is connected to your computer.

### For Mac OS X(v10.0/v10.1) users

You can use only a “Memory Stick” with a computer running Mac OS X(v10.0/v10.1). Even if you insert a floppy disk, Mac OS X(v10.0/v10.1) cannot recognize it. To use data saved on a floppy disk, copy it to a “Memory Stick” first (page 77).

---

#### 1 Double-click the newly recognized icon on the desktop.

The folders in a floppy disk or a “Memory Stick” are displayed.

---

#### 2 Select and double-click the desired image file from the folder.

See “Image file storage destinations and image file names” (page 38) for further information.

#### Viewing an image of a floppy disk

Desired file type	Double-click in this order
E-mail image	“E-mail” folder → Image file
Other files	Image file

## Viewing an image of a “Memory Stick”

Desired file type	Double-click in this order
Still image	“Dcim” folder → “100msdcf” folder → Image file
Moving image*	“Mssony” folder → “Moml0001” folder → Image file*
Clip Motion image	“Dcim” folder → “100msdcf” folder → Image file
E-mail image TIFF image (uncompressed)	“Mssony” folder → “Imcif100” folder → Image file

\* Copying a file to the hard disk of your computer before viewing it is recommended. If you view the file directly from a floppy disk or a “Memory Stick,” the image may break off.

## To copy image data to your computer

Open the folder that contains an image data you want to copy, and drag and drop the image data to the hard disk icon.

The image file is copied to the hard disk.

## Notes on using your computer

### Floppy disk and “Memory Stick”

- Be sure to format a floppy disk and a “Memory Stick” using your camera (page 81). You cannot format a floppy disk or a “Memory Stick” from a computer connected using the USB cable.
- Use the DOS/V format 2HD type floppy disk. A computer cannot correctly recognize a floppy disk other than this type.
- Do not compress the data on the “Memory Stick.” Compressed files cannot be played back on your camera.

# Image file storage destinations and image file names

Image files recorded with your camera are grouped in folders by recording mode. Images in a floppy disk and ones in a “Memory Stick” have different file names. The meanings of the file names are as follows.

## When using floppy disks

□□□ stands for any number within the range from 001 to 999.

△ stands for one of the following characters below.

S: Still image file recorded at 640×480 size

F: Still image file of more than 640×480 size

V: Moving image file recorded at 160×112 size

W: Moving image file recorded at 320×240 size

T: Still image file recorded in TEXT mode

C: Clip Motion file recorded in NORMAL mode

M: Clip Motion file recorded in MOBILE mode

## For Windows Me users (The drive recognizing the floppy disk is [A:].)

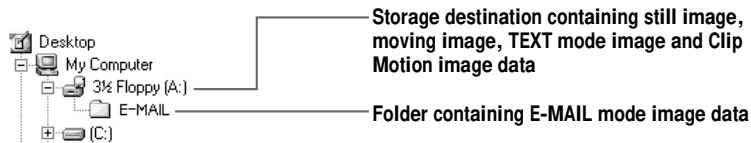

Location	File	Meaning
3 1/2 Floppy [A:]	MVC-□□□△.JPG	<ul style="list-style-type: none"> <li>• Still image file recorded normally</li> <li>• Still image file recorded in E-MAIL mode (page 61)</li> </ul>
	MVC-□□□△.411	<ul style="list-style-type: none"> <li>• INDEX display file</li> <li>This file can only be played back on your camera.</li> </ul>
	MVC-□□□△.MPG	<ul style="list-style-type: none"> <li>• Moving image file</li> </ul>
	MVC-□□□△.GIF	<ul style="list-style-type: none"> <li>• Still image file recorded in               <ul style="list-style-type: none"> <li>— TEXT mode (page 62)</li> <li>— Clip Motion (page 59)</li> </ul> </li> </ul>
	MVC-□□□△.THM	<ul style="list-style-type: none"> <li>• Index image file recorded in               <ul style="list-style-type: none"> <li>— TEXT mode (page 62)</li> <li>— Clip Motion (page 59)</li> </ul> </li> </ul>
E-MAIL folder	MVC-□□□E.JPG	<ul style="list-style-type: none"> <li>• Small-size image file recorded in E-MAIL mode (page 61)</li> </ul>

- The numerical portions of the following files are the same.
  - An image file recorded in E-MAIL mode and its corresponding small-size image file
  - An image file recorded in TEXT mode and its corresponding index image file
  - An image file recorded with Clip Motion and its corresponding index image file
- INDEX display files recorded in the TEXT mode or Clip Motion mode are played back only on this camera.

## When using “Memory Stick”s

□□□□ stands for any number within the range from 0001 to 9999.

### For Windows Me users (The drive recognizing the camera is [D:])

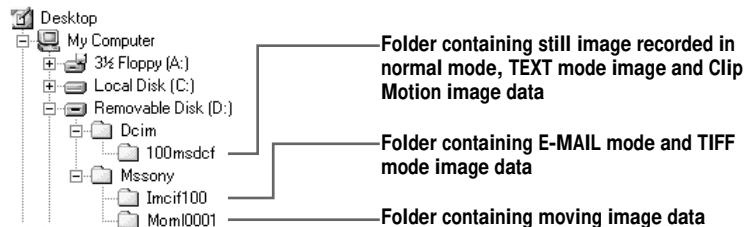

Folder	File	Meaning
100msdcf	DSC0□□□□.JPG	<ul style="list-style-type: none"> <li>• Still image file recorded normally</li> <li>• Still image file recorded in                             <ul style="list-style-type: none"> <li>— E-MAIL mode (page 61)</li> <li>— TIFF mode (page 63)</li> </ul> </li> </ul>
	CLP0□□□□.GIF	• Clip Motion file recorded in NORMAL mode (page 59)
	CLP0□□□□.THM	• Index image file of Clip Motion file recorded in NORMAL mode
	MBL0□□□□.GIF	• Clip Motion file recorded in MOBILE mode (page 59)
	MBL0□□□□.THM	• Index image file of Clip Motion file recorded in MOBILE mode
	TXT0□□□□.GIF	• Still image file recorded in TEXT mode (page 62)
	TXT0□□□□.THM	• Index image file of still image file recorded in TEXT mode

Folder	File	Meaning
Imcif100	DSC0□□□□.JPG	• Small-size image file recorded in E-MAIL mode (page 61)
	DSC0□□□□.TIF	• Uncompressed image file recorded in TIFF mode (page 63)
Mom10001	MOV0□□□□.MPG	• Moving image file recorded normally

The numerical portions of the following files are the same.

- A small-size image file recorded in E-MAIL mode and its corresponding image file
- An uncompressed image file recorded in TIFF mode and its corresponding image file
- An image file recorded in TEXT mode and its corresponding index image file
- An image file recorded with Clip Motion and its corresponding index image file

### **Tips**

The digital still camera saves recorded images as digital data. The format of the saved data is called as the file format. The formats that can be used with this camera are as follows:

#### **JPEG format**

Most digital still cameras, operating systems of computers, and browser software adopt this format. This format is able to compress files without appreciable deterioration. However, if the image is compressed and saved on repeated occasions, the image will deteriorate. This camera records still images using the JPEG format for normal recording.

#### **GIF format**

Using this format, the image will not deteriorate even if the image is compressed and saved on repeated occasions. This format limits the number of colors used to 256 colors. This camera records still images using the GIF format in Clip Motion (page 59) or TEXT mode (page 62).

#### **TIFF format**

Stores shooting images without compression, so the image does not deteriorate. Most of operating systems and applications correspond to this format. This camera records still images using the TIFF format for the TIFF mode (page 63).

#### **MPEG format**

This format is very typical for moving images. This camera records moving images in the MPEG format during the recording.

# Viewing images using “ImageMixer”

## Installing “PIXELA ImageMixer Ver.1.0 for Sony”

You can easily view a still image and/or moving image recorded by your camera using the “PIXELA ImageMixer Ver.1.0 for Sony” provided on the CD-ROM supplied with your camera.

The system requirements of your computer are indicated in the operation manual supplied with the CD-ROM.

### Before operation

If you are using Windows 2000 and Windows XP, log in as an administrator.

---

#### ① Turn on your computer.

Close all applications you are running on your computer.

---

#### ② Insert the supplied CD-ROM in the CD-ROM drive of your computer.

The title screen appears after a moment.

#### If the title screen does not appear

① Double-click “My Computer” on the Desktop.

② Double-click the CD-ROM (“ImageMixer (E:)\*”).

\* The drive symbol ((E:), etc.) may differ depending on your computer.

---

#### ③ Select “PIXELA ImageMixer Ver.1.0 for Sony” in the title screen.

##### For Windows users

#### 1 Click “PIXELA ImageMixer” and install the software in accordance with the instructions displayed on the screen.

After confirming the information in the “Readme.txt” screen displayed at the end of installing process, close this screen and click “Finish.”

**If you are using Windows XP, skip steps 2 to 4 below. Go to step ④.**

#### 2 Click “DirectX” in the title screen.

The “Microsoft DirectX8.0 Setup” screen appears.

#### 3 Click “Yes.”

The “DirectX(R) Setup” screen appears.

#### 4 Click “Install.”

The installation starts. When the installation finishes, click “OK” and restart your computer.

### For Macintosh users

Click the button of the language (such as English) of the version to be installed in the title screen and then install the software in accordance with the instructions displayed in the screen.

---

## 4 Remove the CD-ROM from the computer.

---

### To copy image data to your computer using “ImageMixer”

Use the following procedure of “PIXELA ImageMixer” to copy a still image or moving image data recorded in your camera.

The procedure below is explained using screens displayed by Windows. You can copy the image using a similar procedure for Macintosh also.

#### For Mac OS X(v10.0/v10.1) users

You can use only a “Memory Stick” with a computer running Mac OS X(v10.0/v10.1). Even if you insert a floppy disk, Mac OS X(v10.0/v10.1) cannot recognize it. To use data saved on a floppy disk, copy it to a “Memory Stick” first (page 77).

#### Cautions

- Sometimes an displayed image may be interrupted when you view it on your computer using the USB cable.
- The screen display of your camera is not copied to your computer.

#### If you encounter a trouble

Close “ImageMixer” and restart it to retry.

---

## 1 Prepare your camera and computer.

- 1 Turn on your computer.
  - 2 Insert a floppy disk or a “Memory Stick” in your computer and set the MS/FD selector in accordance with the media you have inserted.
  - 3 Connect the AC power adaptor to your camera and turn on your camera.
  - 4 Connect your camera to your computer using the USB cable.  
“USB MODE” appears on the LCD screen of your camera.
-

## 2 Start “ImageMixer” on your computer.

### For Windows users

Open the nested windows in the following order: “Start” → “Program” → “Pixela” → “ImageMixer” → “PIXELA ImageMixer Ver.1.0 for Sony”.

### For Macintosh users

Click “PIXELA ImageMixer Ver.1.0 for Sony” in the installed folder. “ImageMixer” starts and the main screen is displayed.

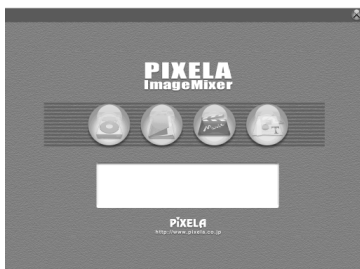

## 3 Click the Capture Environment displayed on the left edge of the screen.

The screen for copying an image is displayed.

## 4 Select a folder that contains an image to be copied.

Click the Import File Mode button  displayed on the left of the screen and select a folder that contains an image to be viewed from the folder list window. A list of the images stored in the selected folder is displayed in the file thumbnail list window.

If the image is stored in a floppy disk or a “Memory Stick” set in your camera, select “Removable Disk (E:)\*”.

\* The drive symbol ((E:), etc.) may differ depending on your computer.

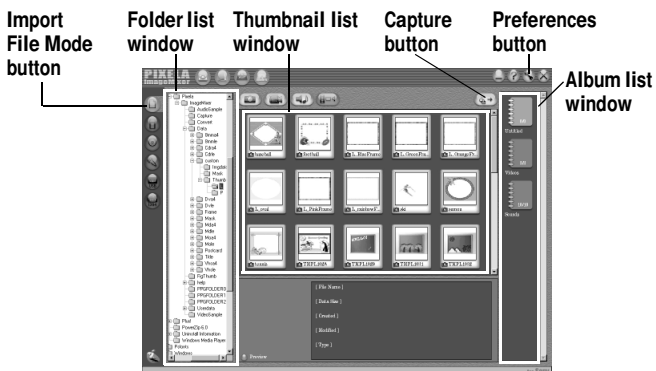

- 5 Click the Preferences button  at the top right of the screen.**  
The “Capturing/Recording Preferences” screen appears.

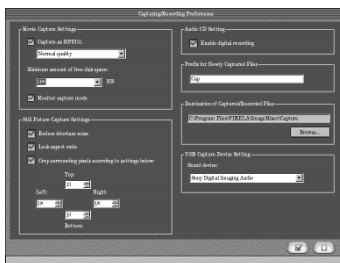

- 6 Select a folder in which the copied image is stored.**  
Click “Browse” for “Destination of Captured/Recorded Files” and click “My Documents” (example) in the “Browse for Folder” screen that is displayed. Then, click “OK.”  
After you finish the setting, click the button  at the bottom right of the screen.

- 7 Click an album in the album list window.**  
Select an album in which you want to save a file.

- 8 Click to select an image to be copied to your computer.**  
You can select two or more images by clicking the images while holding down the Control key for Windows (Option key for Macintosh).

- 9 Click the Capture button  at the upper right of the screen.**  
The image is copied to your computer.  
You can also copy the image by dragging and dropping it from the file thumbnail list window to the album.

## Viewing images using “ImageMixer”

You can use “ImageMixer” to view the image copied to your computer.

- 1 **Click the Album Environment button  in the main screen or image copy screen.**

Select an album that contains an image you want to view.

The screen for viewing images appears.

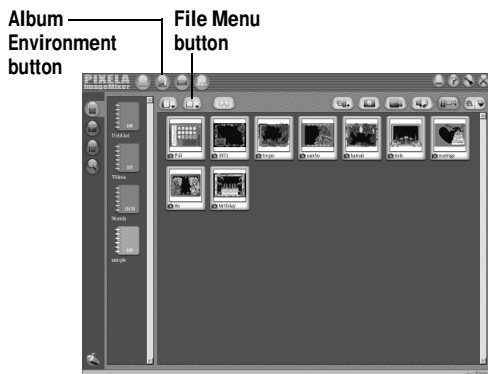

- 2 **Double-click the image to be viewed.**

The selected image is displayed.

### To return to the image list display screen

Click the close button  displayed on the upper right of the screen.

### To print the image

- 1 **Click an image to be printed in the image list display screen.**
- 2 **Click the File Menu button  and click “Print” on the displayed menu.**

The “Print Layout Settings” screen appears.

- 3 **Set the layout.**

Set the layout you prefer. Normally, click the Print Image Only  button under the screen.

- 4 **Click the print setup button  at the lower right of the screen.**

The “Print Setup” screen appears. Set the paper size and printing direction and click “OK.”

## 5 Click the print button at the lower right of the screen.

The “Print” screen appears. Click “OK.”

The image is printed.

## If the image is not printed

Confirm whether the printer setting is correct.

See the operating instructions supplied with your printer for further information.

## Viewing the on-line help of “PIXELA ImageMixer Ver.1.0 for Sony”

You can find detailed information about procedures and functions of “PIXELA ImageMixer Ver.1.0 for Sony.”

### For Windows users

---

#### 1 Click the Help button at the upper right of the screen.

The “ImageMixer Help” screen appears.

---

#### 2 You can access the information you want from the table of contents or click a link displayed in blue characters (site address).

---

### For Macintosh users

Use your web browser to open the manual.html file in the folder in which ImageMixer Ver.1.0 for Sony is installed.

## To close the on-line help

Click the button  for closing the window of “PIXELA ImageMixer Ver.1.0 for Sony”

## If you have any questions about “PIXELA ImageMixer Ver.1.0 for Sony”

ImageMixer Ver.1.0 for Sony is a trademark of PIXELA corporation.

Refer to the information web site at: “<http://www.imagemixer.com>”.

# Before performing advanced operations

This section describes the basic control methods that are frequently used for “Advanced operations.”

---

## How to use the PLAY/STILL/MOVIE selector

The PLAY/STILL/MOVIE selector selects whether you can use your camera to record or play back and edit images. Set the selector as follows before starting to operate your camera.

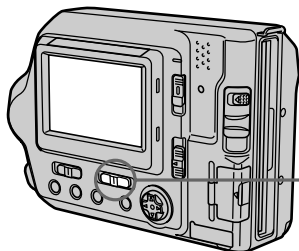

PLAY STILL MOVIE

**PLAY:** To play back or edit images  
**STILL:** To record still images and Clip Motion images  
**MOVIE:** To record moving images

The callout box contains a diagram of the selector switch with three positions: PLAY, STILL, and MOVIE. The MOVIE position is currently selected. Below the diagram are three lines of text, each with a bolded label and a description of its function.

---

## How to use the control button

The control button is used to select the buttons, images and menus displayed on the LCD screen of your camera and modify the settings. The operation methods that are frequently used for “Advanced operations” are described below.

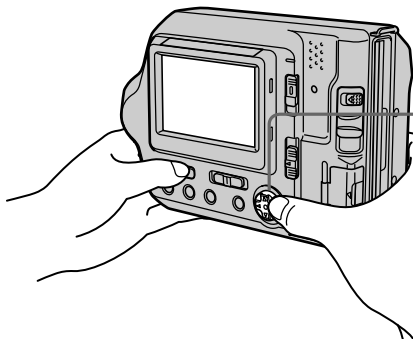

Select      Set (enter)

The callout box contains two circular buttons. The left button is labeled 'Select' and has a left-pointing arrow. The right button is labeled 'Set (enter)' and has a right-pointing arrow.

## Turning on/off the operation buttons (menu bar) on the LCD screen

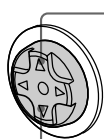

Press ▲ to display the menu bar on the LCD screen.



Press ▼ to clear the menu bar from the LCD screen.

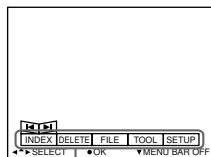

Menu bar

### Note

You cannot clear the menu bar on the INDEX screen (page 70).

## Selecting items or images on the LCD screen

- 1 Press ▲/▼/◀/▶ on the control button to select the item you want to set or the image you want to display.

The color of the selected item or the frame of the selected image changes from blue to yellow.

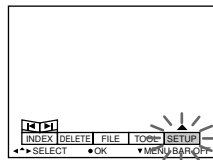

- 2 Press the center ● on the control button to enter the item.

Repeat steps 1 and 2 to execute each function.

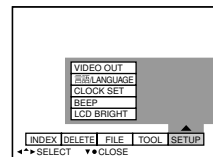

The “Advanced operations” section of this manual refers to selecting and entering items by the above procedure as “Select [item name].”

# How to change the menu settings

Some of the advanced operations for your camera are executed by selecting menu items displayed on the LCD screen with the control button.

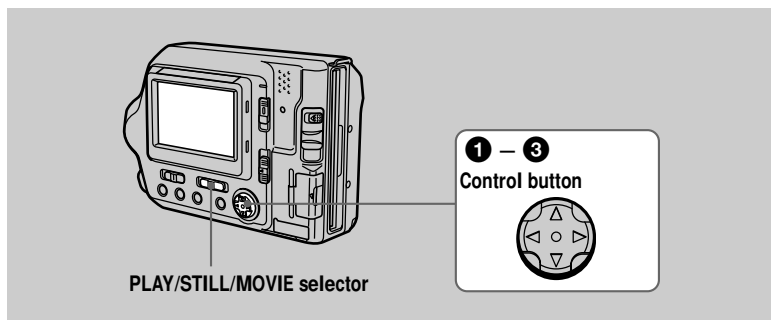

- 1 Press ▲ on the control button to display the menu bar.**  
The menu bar appears as follows according to the position of the PLAY/STILL/MOVIE selector.

### STILL/MOVIE

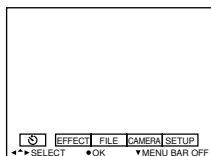

### PLAY (single mode)

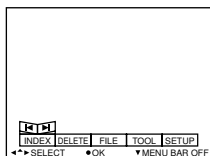

### PLAY (INDEX mode)

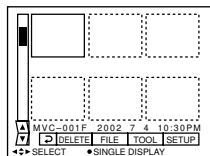

- 2 Select the desired item with ▲/▼/◀/▶ on the control button, then press the center ●.**

The color of the selected item changes from blue to yellow, and when you press the center ●, the settings that can be set for its item are displayed.

### Note

The displayed items are changed according to the position of the MS/FD selector.

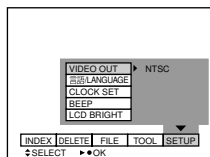

- 3 Select the desired setting with ▲/▼/◀/▶ on the control button, then press the center ●.**

## To cancel the setup

Press ▼ on the control button repeatedly until the LCD screen returns to the menu bar display in step 1. To clear the menu bar, press ▼ again.

## Menu settings

Menu items that can be modified differ depending on the positions of the PLAY/STILL/MOVIE selector or the MS/FD selector. The LCD screen shows only the items you can operate at the moment. Initial settings are indicated with ■.

### (self-timer)

Records with the self-timer (page 21).

## EFFECT

Item	Setting	Description	PLAY/STILL/ MOVIE selector
P. EFFECT	SOLARIZE B&W SEPIA NEG.ART ■ OFF	Sets the image special effects (page 69).	STILL MOVIE
DATE/ TIME	DAY & TIME DATE ■ OFF	Sets whether to insert the date and time into the image (page 69).	STILL

## FILE

Item-1	Item-2	Setting	Description	PLAY/STILL/ MOVIE selector
DISK TOOL (When the MS/FD selector is set to FD.)	FORMAT	OK	Formats a floppy disk (page 81). Once you format a floppy disk, all of the data, including protected images are deleted. Be sure to check for images before you format a floppy disk.	PLAY STILL MOVIE
		CANCEL	Cancels formatting of a floppy disk.	
	DISK COPY	OK	Copies all data stored in a floppy disk to another disk (page 79).	
		CANCEL	Cancels the disk copy.	
	CANCEL		Goes back to the [DISK TOOL] item.	

Item	Setting	Description	PLAY/STILL/ MOVIE selector
FORMAT (When the MS/FD selector is set to MS.)	OK  CANCEL	Formats a "Memory Stick." Once you format the "Memory Stick," all of the data, including protected images are deleted. Be sure to check for images before you format a "Memory Stick."  Cancels formatting of a "Memory Stick."	PLAY STILL MOVIE
FILE NUMBER	SERIES  ■ NORMAL	Assigns numbers to files in sequence even if the floppy disk or the "Memory Stick" is changed. Note that file numbers are not in sequence between a floppy disk and a "Memory Stick."  Resets the file number that starts from 001 or 0001 each time the floppy disk or the "Memory Stick" is changed.	STILL MOVIE
CLIP MOTION	160×120 (NORMAL)  80×72 (MOBILE)  CANCEL	Sets the image size and number of frames for creating GIF format animation (page 59).  Up to 10 frames can be recorded.  Up to 2 frames can be recorded.  Cancels Clip Motion.	STILL
IMAGE SIZE (When the MS/FD selector is set to FD.)	MVC-FD100 ■ 1280×960 1280(3:2) 1024×768 640×480 MVC-FD200 ■ 1600×1200 1600 (3:2) 1600 (ECM) 1024×768 640×480	Selects the image size when recording still images.	STILL

Item	Setting	Description	PLAY/STILL/ MOVIE selector
IMAGE SIZE (When the MS/FD selector is set to MS.)	MVC-FD100 <input checked="" type="checkbox"/> 1280 (FINE) 1280(3:2) F 1024 (FINE) 640 (FINE) MVC-FD200 <input checked="" type="checkbox"/> 1600 (FINE) 1600 (3:2)F 1024 (FINE) 640 (FINE)	Selects the image size when recording still images.	STILL
IMAGE SIZE	320×240 <input checked="" type="checkbox"/> 160×112	Selects the MPEG image size when recording moving images.	MOVIE
REC MODE	TIFF  TEXT  E-MAIL  <input checked="" type="checkbox"/> NORMAL	Records a TIFF (uncompressed) file in addition to the JPEG file when the MS/FD selector is set to MS.  Records a GIF file in black-and-white.  Records a small-size (320×240) JPEG file in addition to the selected image size.  Records an image using the normal recording mode.	STILL
REC TIME SET	15 sec 10 sec <input checked="" type="checkbox"/> 5 sec	Selects the recording time for moving images.	MOVIE
SLIDE SHOW (Only in PLAY (single) mode)	INTERVAL  REPEAT  START  CANCEL	Sets the slide show interval. <input checked="" type="checkbox"/> 3 sec/5 sec/10 sec/30 sec/1 min A slide show can be repeated. (When using the floppy disk, a slide show is up to approx. 20 minutes.) <input checked="" type="checkbox"/> ON/OFF Starts the slide show. Cancels the slide show settings or execution.	PLAY
PRINT MARK	ON  <input checked="" type="checkbox"/> OFF	Marks the still images to be printed (page 80).  Unmarks the print mark of the still images.	PLAY
PROTECT	ON  <input checked="" type="checkbox"/> OFF	Protects images against accidental erasure (page 74).  Releases protection of images.	PLAY

## CAMERA

Item	Setting	Description	PLAY/STILL/ MOVIE selector
ISO	400 200 100 ■ AUTO	Selects the ISO film speed. When recording under dark conditions or recording a fast-moving subject, use a high-number setting. To record high-quality images, use a low-number setting. (You can select this item only when the PROGRAM AE function is canceled or spot light-metering mode is set.)	STILL
DIGITAL ZOOM	■ ON OFF	Uses a digital zoom. Does not use a digital zoom.	STILL
SHARPNESS	+2 to -2	Adjusts the sharpness of the image. The <input type="checkbox"/> indicator appears (except when the setting is 0).	STILL
WHITE BALANCE	IN DOOR OUT DOOR HOLD ■ AUTO	Sets the white balance (page 68).	STILL MOVIE
FLASH LEVEL	HIGH ■ NORMAL LOW	Makes the flash level higher than normal. Normal setting. Makes the flash level lower than normal.	STILL
EXPOSURE	+2.0EV to -2.0EV	Adjusts the exposure before recording.	STILL MOVIE

## TOOL

Item	Setting	Description	PLAY/STILL/ MOVIE selector
COPY (When the MS/FD selector is set to FD.)	FD → FD FD → MS CANCEL	Copies the image to a floppy disk. Copies the image to a "Memory Stick." Cancels copying of the image (page 78).	PLAY
COPY (When the MS/FD selector is set to MS.)	MS → MS MS → FD CANCEL	Copies the image to a "Memory Stick." Copies the image to a floppy disk. Cancels copying of the image (page 78).	PLAY

Item	Setting	Description	PLAY/STILL/ MOVIE selector
RESIZE (When the MS/FD selector is set to FD.)	MVC-FD100 1280×960 1024×768 640×480 CANCEL MVC-FD200 1600×1200 1024×768 640×480 CANCEL	Changes the recorded image size in PLAY (single) mode (page 76).	PLAY
RESIZE (When the MS/FD selector is set to MS.)	MVC-FD100 1280 (FINE) 1024 (FINE) 640 (FINE) CANCEL MVC-FD200 1600 (FINE) 1024 (FINE) 640 (FINE) CANCEL	Changes the recorded image size in PLAY (single) mode (page 76).	PLAY

## SETUP

Item	Setting	Description	PLAY/STILL/ MOVIE selector
DEMO	■ STBY/ON OFF	Displayed only when you use the AC power adaptor in STILL or MOVIE mode. When [ON] is selected, a demonstration will start if you do not operate your camera for about 10 minutes. To stop the demonstration, turn off your camera.	STILL MOVIE
VIDEO OUT	NTSC  PAL	Sets the video output signal to NTSC mode (e.g., the U.S.A., Japan).  Sets the video output signal to PAL mode (e.g., Europe).	PLAY STILL MOVIE
言語 / LANGUAGE	■ ENGLISH 日本語 /JPN	Displays the menu items in English. Displays the menu items in Japanese.	PLAY STILL MOVIE
CLOCK SET	—	Sets the date and time (page 14).	PLAY STILL MOVIE

Item	Setting	Description	PLAY/STILL/ MOVIE selector
BEEP	SHUTTER	Turns on the shutter sound only. (The shutter sound is heard when you press the shutter button.)	PLAY STILL MOVIE
	■ ON	Turns on the beep/shutter sound (when you press the control button/shutter button).	
	OFF	Turns off the beep/shutter sound.	
LCD BRIGHT	■■■■■■■■■■	Adjusts the LCD screen brightness using -/+ on the LCD screen.	PLAY STILL MOVIE

### INDEX (Only in PLAY (single) mode)

Displays six images at a time (PLAY (INDEX) mode).

### DELETE (Only in PLAY (single) mode)

Setting	Description	PLAY/STILL/MOVIE selector
OK	Deletes the displayed image.	PLAY
CANCEL	Cancels deleting of the image.	

### ↶ (Return) (Only in PLAY (INDEX) mode)

Returns to PLAY (single) mode.

## ► Various recording

### Setting the image size (IMAGE SIZE)



- 1 Set the **PLAY/STILL/MOVIE** selector to **STILL** or **MOVIE**.
- 2 Select **[FILE]** and then **[IMAGE SIZE]** from the menu.
- 3 Select the desired image size.

#### Still image sizes:

##### • MVC-FD100

When the **MS/FD** selector is set to **FD**

- 1280×960: 1.2 mega pixels
- 1280 (3:2)\*
- 1024×768: 0.8 mega pixels
- 640×480: 0.35 mega pixels

When the **MS/FD** selector is set to **MS**

- 1280 (FINE): 1.2 mega pixels
- 1280 (3:2)\*F
- 1024 (FINE): 0.8 mega pixels
- 640 (FINE): 0.35 mega pixels

##### • MVC-FD200

When the **MS/FD** selector is set to **FD**

- 1600×1200: 2.0 mega pixels
- 1600 (3:2)\*
- 1600 (ECM)
- 1024×768: 0.8 mega pixels
- 640×480: 0.35 mega pixels

When the **MS/FD** selector is set to **MS**

- 1600 (FINE): 2.0 mega pixels
- 1600 (3:2)\*
- 1024 (FINE): 0.8 mega pixels
- 640 (FINE): 0.35 mega pixels

**(FINE):** The images recorded on a “Memory Stick” have a higher picture quality. The size of a file that can be recorded on a “Memory Stick” is also larger than that of a floppy disk.

**(ECM):** The picture quality is lower, but more images can be recorded. If picture quality is more important than the number of images to be recorded, select [1600×1200].

\* Your camera will record an image using a 3:2 ratio so that it matches the horizontal and vertical ratio 3:2 of print paper. Therefore, there will be no margin when the image is printed in the print paper. Please note that the top and bottom of the recording range displayed on the LCD screen (horizontal and vertical ratio 4:3) is cut off when the image is recorded in your camera.

#### Moving image sizes:

320×240, 160×112

**The number of images or the time that you can record on a floppy disk or a “Memory Stick” (8 MB)**

**MVC-FD100**

Image size	Usage	Number of images to be recorded or time*1)	
		Floppy disk	“Memory Stick”
1280×960	Printing in post card size	Approx. 6	Approx. 12
1280 (3:2)	Printing in 3:2 ratio	Approx. 6	Approx. 12
1024×768	Home page, etc.	Approx. 10	Approx. 20
640×480	Attaching to e-mail	Approx. 30	Approx. 48
320×240*2)	Viewing on computer	Approx. 15 sec.	Approx. 80 sec. (Approx. 15 sec.)*3)
160×112*2)	Attaching to e-mail	Approx. 60 sec.	Approx. 320 sec. (Approx. 60 sec.)*3)

**MVC-FD200**

Image size	Usage	Number of images to be recorded or time*1)	
		Floppy disk	“Memory Stick”
1600×1200	Printing in size A4	Approx. 4	Approx. 8
1600 (3:2)	Printing in 3:2 ratio	Approx. 4	Approx. 8
1600 (ECM)	Recording a large number of images	Approx. 8	–
1024×768	Home page, etc.	Approx. 10	Approx. 20
640×480	Attaching to e-mail	Approx. 30	Approx. 48
320×240*2)	Viewing on computer	Approx. 15 sec.	Approx. 80 sec. (15 sec.)*3)
160×112*2)	Attaching to e-mail	Approx. 60 sec.	Approx. 320 sec. (60 sec.)*3)

\*1) When REC MODE is set to NORMAL.

\*2) Image size of a moving image.

\*3) The maximum recording time in continuous recording.

**Recording time and number of images to be recorded**

The recording time and the number of images to be recorded may differ from the above values depending on the recording conditions.

**Notes**

- If you try to record 55 images or more on a floppy disk, even if the remaining disk capacity is sufficient, “DISK FULL” appears on the LCD screen and you cannot record any more images.
- If you try to record 3001 images or more on a “Memory Stick,” even if the remaining memory capacity of the “Memory Stick” is sufficient, “NO MEMORY SPACE” appears on the LCD screen and you cannot record any more images.
- When the TEXT mode is selected, the number of images that can be recorded will be the same as that of [1600×1200] even if you select [1600 (ECM)] for image size.

### Tips

The size of the image is indicated by the pixel unit. The higher the number of pixels, the more information is included. So, an image that is saved using a large number of pixels is suitable for a large-format print and one that is saved using a smaller number of pixels is suitable for attaching to an E-mail. Normally, an image is recorded in the ratio of four to three to fit the monitor ratio. This camera can also record the image in the ratio of three to two to accommodate the most common printing paper size. This is the same ratio as the one used in photo-developing shops.



1280×960



1280 (3:2)

## Creating Clip Motion Files

Clip Motion is an animation function that plays back still images in succession. Clip Motion images are played back on this camera at approximately 0.5 s intervals. The images are stored in GIF format, which is convenient for creating home pages or attaching images to an e-mail.

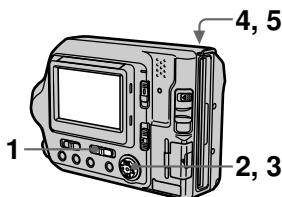

- 1 Set the **PLAY/STILL/MOVIE** selector to **STILL**.
- 2 Select [**FILE**] and then [**CLIP MOTION**] from the menu.
- 3 Select the desired mode.  
**160×120 (NORMAL)**  
Clip Motion of up to 10 frames can be recorded.  
This is suitable for use on home pages, etc.  
**80×72 (MOBILE)**  
Clip Motion of up to 2 frames can be recorded.  
This is suitable for use with portable data terminals.

### CANCEL

This cancels the creation of Clip Motion.

#### 4 Record the image for the first frame.

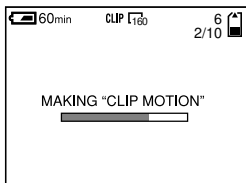

#### 5 Record the image for the next frame.

Image recording can be repeated up to the maximum number of recordable frames.

The frame images are automatically recorded on the floppy disk or the "Memory Stick" when you select [FINISH] or after recording the maximum number of frames.

### To stop Clip Motion creation

Select [RETURN] after step 3.

Note that if you record even one frame, you cannot stop Clip Motion creation.

### The number of Clip Motion frames that you can record on a floppy disk or a "Memory Stick" (8 MB)

Image size	Number of images	
	Floppy disk	"Memory Stick"
160×120 (NORMAL)	Approx. 7*	Approx. 40*
80×72 (MOBILE)	Approx. 54**	Approx. 400**

\* When recording 10 frames per Clip Motion file

\*\* When recording 2 frames per Clip Motion file

### Notes

- Reading and writing data takes more time than normal image recording.
- Due to the limitations of the GIF format, the number of colors for Clip Motion images is reduced to 256 colors or less. Therefore, the picture quality may deteriorate for some images.
- The file size is reduced in MOBILE mode, so the picture quality deteriorates.
- GIF files not created on this camera may not be displayed correctly.

## Recording still images for e-mail (E-MAIL)

The E-MAIL mode records a small-size (320×240) image at the same time as a still image. Small-size images are convenient for e-mail transmission, etc. Images in E-MAIL mode are recorded in the JPEG format.

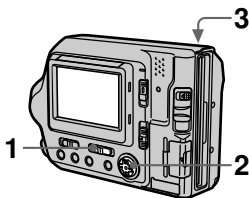

- 1 Set the PLAY/STILL/MOVIE selector to STILL.
- 2 Select [FILE], [REC MODE], and then [E-MAIL] from the menu.
- 3 Record the image.

The number of images that you can record on a floppy disk or a "Memory Stick" (8 MB) in E-MAIL mode

### MVC-FD100

Image size	Number of images	
	Floppy disk	"Memory Stick"
1280×960	Approx. 5	Approx. 12
1280 (3:2)	Approx. 5	Approx. 12
1024×768	Approx. 8	Approx. 20
640×480	Approx. 22	Approx. 43

### MVC-FD200

Image size	Number of images	
	Floppy disk	"Memory Stick"
1600×1200	Approx. 3	Approx. 8
1600 (3:2)	Approx. 3	Approx. 8
1600 (ECM)	Approx. 7	—
1024×768	Approx. 8	Approx. 20
640×480	Approx. 22	Approx. 43

### To return to normal recording mode

Select [NORMAL] in step 2.

## Recording text documents (TEXT)

Text is recorded in GIF format to provide a clear image.

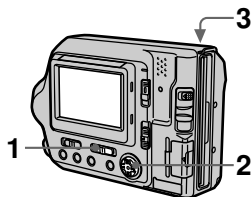

- 1 Set the PLAY/STILL/MOVIE selector to STILL.
- 2 Select [FILE], [REC MODE], and then [TEXT] from the menu.
- 3 Record the image.

The number of images that you can record on a floppy disk or a "Memory Stick" (8 MB) in TEXT mode

### MVC-FD100

Image size	Number of images*	
	Floppy disk	"Memory Stick"
1280×960	Minimum 7	Minimum 36
1280 (3:2)	Minimum 8	Minimum 40
1024×768	Minimum 11	Minimum 54
640×480	Minimum 28	Minimum 121

### MVC-FD200

Image size	Number of images*	
	Floppy disk	"Memory Stick"
1600×1200	Minimum 4	Minimum 24
1600 (3:2)	Minimum 5	Minimum 26
1600 (ECM)	Minimum 4	—
1024×768	Minimum 11	Minimum 54
640×480	Minimum 28	Minimum 121

\* The maximum number of recordable images depends on the document condition, such as the amount of text portions.

### To return to normal recording mode

Select [NORMAL] in step 2.

### Notes

- If the subject is not evenly illuminated, you may be unable to record a clear image.
- Writing and reading data take more time than normal recording.
- When TEXT mode is selected, you cannot use the PROGRAM AE function.

## Recording still images as uncompressed files (TIFF)

This mode simultaneously records still images in both TIFF format (uncompressed) and JPEG format (compressed) **when using a “Memory Stick.”**

Since this mode records images without compressing data, the quality of picture will hardly deteriorate. Use this mode when you want to print images with photograph picture quality.

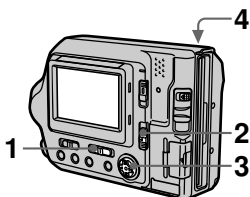

- 1 Set the PLAY/STILL/MOVIE selector to **STILL**.
- 2 Set the MS/FD selector to **MS**.
- 3 Select [FILE], [REC MODE], and then [TIFF] from the menu.
- 4 Record the image.

The number of images that you can record on a “Memory Stick” (8 MB) in TIFF mode

### MVC-FD100

Image size	Number of images
1280×960	1
1280 (3:2)	2

### MVC-FD200

Image size	Number of images
1600×1200	1
1600 (3:2)	1

### To return to normal recording mode

Select [NORMAL] in step 3.

### Notes

- JPEG images are recorded using the image size selected in the [IMAGE SIZE] menu (page 57). Images are automatically recorded using the image size [1280×960] unless [1280 (3:2)] is selected for MVC-FD100. Images are automatically recorded using the image size [1600×1200] unless [1600 (3:2)] is selected for MVC-FD200.
- Writing data takes more time than in normal recording.

## Recording images in macro

Use this mode when you record a small subject such as flower or insect from close up.

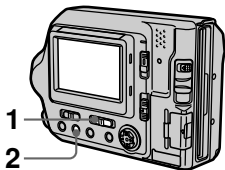

- 1 Set the **PLAY/STILL/MOVIE** selector to **STILL** or **MOVIE**.
- 2 Press **FOCUS** repeatedly until the  (macro) indicator appears on the LCD screen. With the zoom lever set to the **W** side, you can shoot a subject that is about 3 cm (1 3/16 inch) away from the lens surface in macro mode.

### To return to normal recording mode

Press **FOCUS** repeatedly until both the  and  indicators disappear.

#### Notes

- You cannot record images in macro with the following **PROGRAM AE** modes:
  - Landscape mode
  - Panfocus mode
- You cannot record images in macro if the  indicator appears.

## Setting the distance to the subject

The focus is automatically adjusted. This function is useful when you record a subject by presetting the recording distance in accordance with the distance to the subject or the auto focus does not work well.

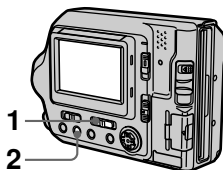

- 1 Set the **PLAY/STILL/MOVIE** selector to **STILL** or **MOVIE**.
- 2 Press **FOCUS** repeatedly until a sharp focus is achieved. The manual focus indicator appears on the LCD screen. You can select from six focus settings:  (macro), 0.5 m, 1.0 m, 3.0 m, 7.0 m, and  $\infty$  (infinity).

### To reactivate auto focusing

Press **FOCUS** repeatedly until both the  and  indicators disappear.

#### Notes

- Focal point information may not completely show the correct distance. Use the information as a guide.
- Focal point information does not show the correct distance when attaching the conversion lens (optional).
- If you shoot a subject within 0.8 m (31 1/2 inches) while the zoom lever is set to **T** side, you cannot get a clear focus. In such cases, the focal point information flashes. Move the zoom lever to the **W** side until the indicator stops flashing.
- You cannot use this function if you have selected the Panfocus mode in the **PROGRAM AE** function.

## Using the PROGRAM AE function

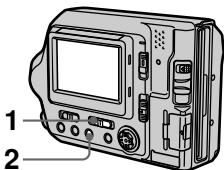

- 1 Set the **PLAY/STILL/MOVIE** selector to **STILL**.
- 2 Press **PROGRAM AE** repeatedly to select the desired **PROGRAM AE** mode.

### **Twilight mode**

Suppresses the blurring of colors of a bright subject in a dark place so that you can record the subject without losing the dark atmosphere of the surroundings.

### **Twilight plus mode**

Increases the effectiveness of the twilight mode function.

### **Landscape mode**

Focuses only on a distant subject to record landscapes, etc.

### **Panfocus mode**

Changes the focus quickly and simply from a close subject to a distant subject.

### **Spot light-metering mode**

Select this mode when there is backlight or when there is strong contrast between the subject and the background, etc. Position the point you want to record at the spot light-metering cross hair.

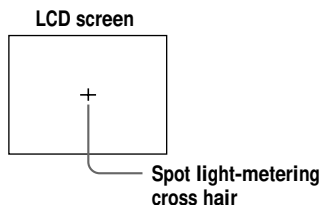

## To cancel PROGRAM AE

Press PROGRAM AE repeatedly until the indicator on the LCD screen goes out.

### **Notes**

- You can focus only on distant subjects in Landscape mode.
- In Panfocus mode, the zoom position is set to the W side and focus is fixed.
- When you record in Twilight plus mode, we recommend that you use a tripod to prevent shaking.
- Set the forced flash  when you use the flash in the following modes:
  - Twilight mode
  - Twilight plus mode
  - Landscape mode
- You cannot use the PROGRAM AE function when the moving or still image of TEXT mode is recorded.
- The ISO film speed is set to AUTO when a PROGRAM AE function other than the spot light-metering mode is set.

### **Tips**

Under normal recording conditions, the camera automatically makes various adjustments, such as those for the focus, iris, exposure, and white balance, as it shoots. However, you may not be able to carry out your desired shooting depending on shooting conditions. The PROGRAM AE function provides you with near-optimum adjustments to suit your shooting situation.



## Adjusting the exposure (EXPOSURE)



- 1** Set the **PLAY/STILL/MOVIE** selector to **STILL** or **MOVIE**.
- 2** Select **[CAMERA]** and then **[EXPOSURE]** from the menu.
- 3** Select the desired exposure value.

Adjust the exposure value while checking the brightness of the background. You can select values ranging from +2.0 EV to -2.0 EV in steps of 1/3 EV.

### Note

If a subject is under extremely bright or dark situations, or the flash is used, the exposure adjustment may not be effective.

### Tips

Normally, the camera automatically adjusts the exposure. If the color of the image is too dark or bright as shown below, we recommend that you adjust the exposure manually. When recording a backlit subject or a subject in the snow, set the exposure toward +, and when recording a subject with extremely bright illumination such as a spotlight, set it toward -.

#### Set the exposure toward +



#### Set the exposure toward -

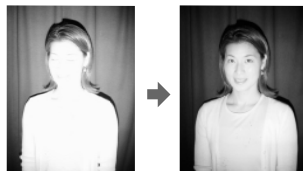

## Adjusting the white balance (WHITE BALANCE)

When the white balance mode is set to AUTO, your camera automatically sets white balance in accordance with the recording conditions and adjusts the balance of all colors in an image. If you want to fix the recording conditions or record an image in specific lighting conditions, you can set the desired white balance mode.



- 1** Set the **PLAY/STILL/MOVIE** selector to **STILL** or **MOVIE**.
- 2** Select **[CAMERA]** and then **[WHITE BALANCE]** from the menu.
- 3** Select the desired white balance setting.

### **IN DOOR** (☀)

- Places where the lighting condition changes quickly
- Under bright lighting such as photography studios
- Under sodium or mercury lamps

### **OUT DOOR** (☀)

Recording a sunrise/sunset, night scene, neon signs, or fireworks

### **HOLD (HOLD)**

Retains the adjusted white balance value

### **AUTO (No indicator)**

Adjusts the white balance automatically

## To reactivate auto adjustment

Select **[AUTO]** in step **3**.

### **Tips**

The image is affected by the lighting conditions. The image looks blue under sunlight in the summer, and looks red under mercury lamps. Human eyes can resolve these problems. However, the camera cannot resolve the problem without making adjustments. Normally, the camera adjusts automatically, but if the image appears in strange colors, we recommend that you change the white balance mode.

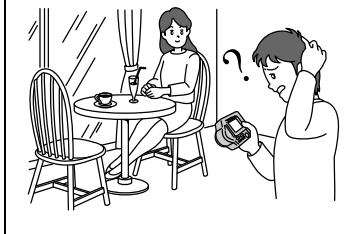

## Recording the date and time on the still image (DATE/TIME)

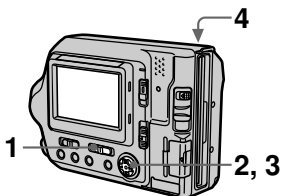

- 1 Set the **PLAY/STILL/MOVIE** selector to **STILL**.
- 2 Select [**EFFECT**] and then [**DATE/TIME**] from the menu.
- 3 Select the date and time.

### DAY & TIME

Superimposes the date, hour, and minute.

### DATE

Superimposes the year, month, and day.

### OFF

Does not superimposes the date and time.

- 4 **Record the image.**  
The date and time do not appear on the LCD screen during shooting. These appear during playback only.



### Notes

- When [**DATE**] is selected in step **3**, the date is imposed in the order set by the **CLOCK SET** item (page 14).
- The date and time are not imposed onto Clip Motion images.

## Enjoying picture effects (PICTURE EFFECT)



- 1 Set the **PLAY/STILL/MOVIE** selector to **STILL** or **MOVIE**.
- 2 Select [**EFFECT**] and then [**P. EFFECT**] from the menu.
- 3 Select the desired mode.

### SOLARIZE

The light contrast is clearer and the picture looks like an illustration.

### B&W

The picture is monochrome (black and white).

### SEPIA

The picture is sepia-toned like an old photograph.

### NEG.ART

The color and brightness of the picture are reversed as in a negative.

### OFF

Does not use the picture effect function.

## To cancel picture effect

Select [**OFF**] in step **3**.

## ► Various playback

### Playing back six images at once (INDEX)

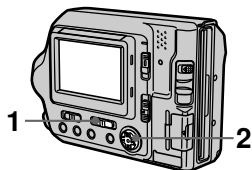

**1 Set the PLAY/STILL/MOVIE selector to PLAY.**

**2 Select [INDEX] on the LCD screen.**

Six images are displayed at once (index screen).

Only the first frame of Clip Motion files is displayed.

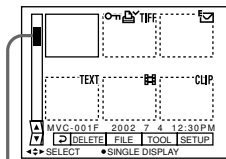

**This shows the position of the currently displayed images relative to all the recorded images.**

The following marks are displayed on each image according to the image type and settings.

: Moving image file

: E-mail file

: Print mark

: Protect mark

TEXT: TEXT file

TIFF: TIFF file

CLIP: Clip Motion file

(No mark): Normal recording (no settings)

### To display the next (previous) index screen

Select ▲/▼ at the lower-left on the LCD screen.

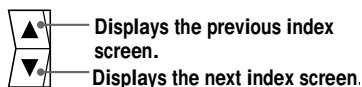

### To return to normal playback (single image)

- Select the desired image with the control button.
- Select (Return).

#### **Note**

When viewing an image recorded in Clip Motion or TEXT mode on the INDEX screen, the image may appear different from the actual image.

## Enlarging a part of the still image (Zoom and trimming)

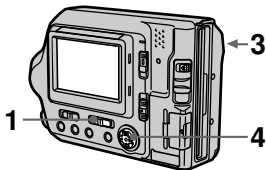

- 1 Set the PLAY/STILL/MOVIE selector to PLAY.**
- 2 Display the image to be enlarged.**
- 3 Zoom in/out the image with the zoom lever.**  
The zoom scaling indicator appears on the LCD screen.
- 4 Press the control button repeatedly to select the desired portion of the image.**
  - ▲: The image moves downward
  - ▼: The image moves upward
  - ◀: The image moves rightward
  - ▶: The image moves leftward

### To return to the normal size

Zoom out with the zoom lever until the zoom scaling indicator ( $\times 1.1$ ) disappears from the screen, or simply press the center  $\bullet$ .

### To record an enlarged image (trimming)

- ① Enlarge the image.
- ② Press the shutter button. The image is recorded at 640×480 size and the image on the LCD screen returns to the normal size after recording.

### Notes

- You cannot trim moving images, still images recorded in Clip Motion, TEXT mode, or uncompressed images.
- Zoom scaling is up to 5× regardless of the original image size.
- The quality of enlarged images may be deteriorated.
- The original data is left even if you enlarge the image.
- The enlarged image is recorded as the newest file.

## Playing back the still images in order (SLIDE SHOW)

This function plays back the recorded still images one after another. This function is useful for checking the recorded images or for presentations, etc.



- 1 Set the PLAY/STILL/MOVIE selector to PLAY.**
- 2 Select [FILE] and then [SLIDE SHOW] from the menu.**

Set the following items.

### INTERVAL

You can select from 1 min (one minute), 30 sec (30 seconds), 10 sec (10 seconds), 5 sec (5 seconds), or 3 sec (3 seconds).

### REPEAT

**ON:** Plays back images continuously in a loop until [RETURN] is selected (the slide show stops automatically after approximately 20 minutes\* when the image is played back from a floppy disk).

**OFF:** After all images have been played back, the slide show ends.

\* The slide show does not end until all the images are played back, even if it takes more than 20 minutes.

- 3 Select [START].**  
The slide show begins.

## To cancel the slide show

Select [CANCEL] in step 2 or 3.

## To skip to the next/previous image during the slide show

Select [◀/▶] at the lower-left on the LCD screen.

### Note

The interval setting time may vary depending on the image size.

## Viewing images on a TV screen

You can play back the recorded images by connecting your camera to the TV. Before connecting your camera, be sure to turn off the TV, connect the VIDEO connecting cable, and turn on the TV.

Set the TV/VIDEO switch to "VIDEO".

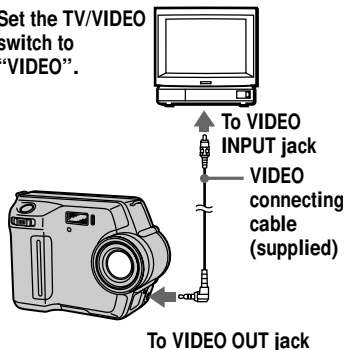

**1** Connect the VIDEO connecting cable to the VIDEO OUT jack of your camera and to the VIDEO INPUT jack of the TV.

**2** Turn on the TV and start playback on your camera.

The playback image appears on the TV screen.

### Note

- You cannot use a TV that has an antenna (aerial) connector only.
- When viewing a still image on the TV, the black band may appear around the image.

## ► Editing

### Preventing accidental erasure (PROTECT)

This function is used to prevent any valuable images that you have recorded from being erased accidentally.

The  (protect) indicator appears on protected images.

#### Note:

If you format a floppy disk or a “Memory Stick”, all images are erased even when they are protected.



#### In single mode

- 1 Set the **PLAY/STILL/MOVIE selector to PLAY**, then display the image to be protected.
- 2 Select **[FILE]**, **[PROTECT]**, and then **[ON]** from the menu. The displayed image is protected and the  indicator appears.

#### To release protection

Select **[OFF]** in step 2.

#### In INDEX mode

- 1 Set the **PLAY/STILL/MOVIE selector to PLAY**, then display the **INDEX screen**.

- 2 Select **[FILE]**, **[PROTECT]**, and then **[ALL]** or **[SELECT]** from the menu.

- 3 When you select **[ALL]** Select **[ON]**.

All the images in the floppy disk or the “Memory Stick” are protected.

#### When you select [SELECT]

Select all the images to be protected with the control button, then select **[ENTER]**. The selected images are protected.

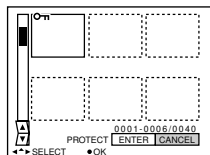

#### To release protection

If you selected **[ALL]** in step 2, select **[OFF]**. If you selected **[SELECT]** in step 2, select the images to be unprotected with the control button, then select **[ENTER]**.

## Deleting images (DELETE)

You can delete the images that are no longer required.  
Protected images cannot be deleted.



### In single mode

- 1 Set the **PLAY/STILL/MOVIE** selector to **PLAY**, then display the image to be deleted.
- 2 Select **[DELETE]** and then **[OK]** from the menu.  
The image is deleted.

### In INDEX mode

- 1 Set the **PLAY/STILL/MOVIE** selector to **PLAY**, then display the **INDEX** screen.
- 2 Select **[DELETE]** and then **[ALL]** or **[SELECT]** from the menu.

- 3 **When you select [ALL]**  
Select **[ENTER]**.  
All the unprotected images are deleted.

**When you select [SELECT]**  
Select all the images to be deleted with the control button, then select **[ENTER]**. The  (delete) indicator appears on the selected images and these images are deleted.

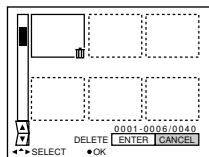

### To cancel deleting

Select **[CANCEL]** in step **2** or **3**.

#### Note

If there are files on the "Memory Stick" with names having the same last 4 digits as the file name of the image to be deleted, these files are also deleted at the same time.

## Changing the recorded still image size (RESIZE)

Use this function when you need a small-size image to attach it to an E-mail. The original image is retained even after resizing. The resized image is recorded as the newest file.



- 1 Set the PLAY/STILL/MOVIE selector to PLAY, then display the image of which you want to change the size.**
- 2 Select [TOOL] and then [RESIZE] from the menu.**
- 3 Select the desired size.**
  - MVC-FD100:**
    - When the MS/FD selector is set to FD**  
1280×960, 1024×768, 640×480
    - When the MS/FD selector is set to MS**  
1280 (FINE), 1024 (FINE),  
640 (FINE)
  - MVC-FD200:**
    - When the MS/FD selector is set to FD**  
1600×1200, 1024×768, 640×480
    - When the MS/FD selector is set to MS**  
1600 (FINE), 1024 (FINE),  
640 (FINE)

The resized image is recorded, then the display returns to the image display before resizing.

## To cancel changing the size

Select [CANCEL] in step 3.

### Notes

- You cannot change the size of images recorded in TEXT mode, moving images, uncompressed images, or Clip Motion images.
- When you change from a small size to a large size, the picture quality deteriorates.
- If you resize the recorded still image, the space remaining on a floppy disk or a “Memory Stick” will decrease.
- You may not be able to resize a recorded still image if there is insufficient space remaining on a floppy disk or a “Memory Stick.”
- You cannot resize the recorded still image to an image size of 3:2.
- If you resize a 3:2 size recorded still image to another size, a black band will be displayed above and below the resized image.
- You cannot resize the recorded still image in the index screen.

## Copying images (COPY)

Copies images to another floppy disk or "Memory Stick."

### In single mode

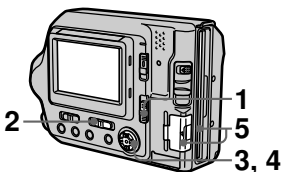

- 1 Select the media using the MS/FD selector.
- 2 Set the PLAY/STILL/MOVIE selector to PLAY, then display the image to be copied.
- 3 Select [TOOL], and then [COPY] from the menu.

- 4 Select the media that the image will be copied onto.
  - When the MS/FD selector is set to FD.  
FD → FD  
Copies to the floppy disk  
FD → MS  
Copies to the "Memory Stick"
  - When the MS/FD selector is set to MS.  
MS → MS  
Copies to the "Memory Stick"  
MS → FD  
Copies to the floppy disk

When you select [FD → MS] or [MS → FD], the camera automatically starts copying if the floppy disk and "Memory Stick" are inserted.

- 5 Insert or change the floppy disk or the "Memory Stick" following the messages on the LCD screen.

"RECORDING" appears. When copying is completed, "COMPLETE" appears. To end copying, select [EXIT].

### To continue copying the image to other floppy disks or "Memory Stick"s

After "COMPLETE" appears in step 5, select [CONTINUE] and repeat step 5 above.

## In INDEX mode

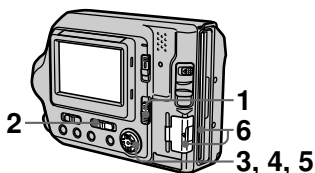

- 1 Select the media using the MS/FD selector.**
- 2 Set the PLAY/STILL/MOVIE selector to PLAY, then display the INDEX screen.**
- 3 Select [TOOL], and then [COPY] from the menu.**
- 4 Select the media that the image will be copied onto.**
  - **When the MS/FD selector is set to FD.**  
**FD → FD**  
Copies to the floppy disk  
**FD → MS**  
Copies to the “Memory Stick”
  - **When the MS/FD selector is set to MS.**  
**MS → MS**  
Copies to the “Memory Stick”  
**MS → FD**  
Copies to the floppy disk

## 5 When you select [ALL]\*

Select [OK].

\* [ALL] can be selected only when selecting [FD → FD] or [FD → MS].

## When you select [SELECT]\*\*

Select all the images to be copied with the control button. The ✓ mark appears on the selected images and then select [ENTER].

\*\* When selecting [MS → FD], the necessary number of floppy disks appears after selecting [ENTER]. Select [OK] again.

## 6 Insert or change the floppy disk or the “Memory Stick” following the messages on the LCD screen.

“RECORDING” appears. When copying is completed, “COMPLETE” appears. To end copying, select [EXIT].

## To continue copying the image to other floppy disks or “Memory Stick”s

After “COMPLETE” appears in step 6, select [CONTINUE] and repeat step 6.

When selecting [MS → FD], if the amount of total images that will be copied is too large to copy to one floppy disk, the images will be copied using multiple floppy disks.

## To cancel copying partway

Select [CANCEL].

## Notes

- You cannot copy uncompressed images.
- You cannot copy the image that is bigger than 1.4 MB.
- You cannot copy the images that the total amount of the images is bigger than 1.4 MB. If “NOT ENOUGH MEMORY” appears or ✓ flashes on the INDEX screen, cancel some images to copy and try again.
- If you eject and insert the floppy disk or the “Memory Stick” without selecting [EXIT] after “COMPLETE” appears, the image will be copied.
- The number of floppy disks that is needed for copying is as a guide, which is displayed when selecting [MS → FD].

## Copying all the information on your floppy disk (DISK COPY)

You can copy to another disk not only the images you have recorded with your camera but also various files you have created in other software with your computer.

### Notes

- Once you carry out DISK COPY, all information saved on the recipient floppy disk is erased to be replaced by newly written data including the protected image data. Check the contents of the recipient disk before copying the disk.
- Be sure to use the floppy disk that has been formatted by this camera to carry out DISK COPY (page 81).

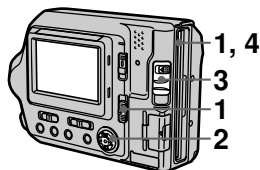

- 1** Set the MS/FD selector to FD, then insert the floppy disk to be copied.
- 2** Select [FILE], [DISK TOOL], [DISK COPY], and then [OK] from the menu.  
“DISK ACCESS” appears.
- 3** When “CHANGE FLOPPY DISK” is displayed, eject the floppy disk.  
“INSERT FLOPPY DISK” appears.

- 4 Insert another floppy disk.**  
“RECORDING” appears. When copying is completed, “COMPLETE” appears.  
To end copying, select [EXIT].

### To continue copying to other floppy disks

After “COMPLETE” appears in step **4**, select [CONTINUE] and repeat steps **3** and **4** above.

### To cancel copying partway

Select [CANCEL].

#### Note

If you eject and insert the floppy disk without selecting [EXIT] after “COMPLETE” appears, DISK COPY will be carried out onto the floppy disk.

## Selecting still images to print (PRINT MARK)

You can mark a print mark on still images recorded with your camera. This mark is convenient when you have images printed at a shop that conforms with the DPOF (Digital Print Order Format) standard.

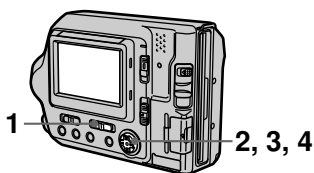

### In single mode

- 1 Set the PLAY/STILL/MOVIE selector to PLAY and display the image you want to print.**
- 2 Select [FILE], [PRINT MARK], and then [ON] from the menu.**  
The  (print) mark is marked on the displayed image.

### To unmark the print mark

Select [OFF] in step 2.

### In INDEX mode

- 1 Set the PLAY/STILL/MOVIE selector to PLAY, then display the INDEX screen.**
- 2 Select [FILE], [PRINT MARK], and then [SELECT] from the menu.**
- 3 Select the images to be marked with the control button.**

#### 4 Select [ENTER].

The  marks on the selected images change from green to white.

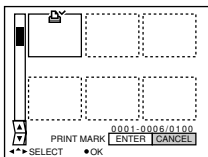

#### To unmark selected print marks

Select the images to be unmarked in step 3 with the control button, then select [ENTER].

#### To unmark all the print marks

Select [FILE], [PRINT MARK], [ALL], and then [OFF] from the menu. The  marks on all images are removed.

#### To print out using the FVP-1 Mavica Printer

Set PRESET SELECT SW to PC on the printer.

#### Notes

- You cannot mark moving images, Clip Motion images or images recorded in TEXT mode.
- If you mark an image recorded in TIFF mode with a print mark, only the uncompressed image is printed, and the JPEG image recorded at the same time is not printed.

## Format

When you format a floppy disk or a “Memory Stick,” all data stored on the floppy disk or the “Memory Stick” will be deleted. Check the contents of the floppy disk or the “Memory Stick” before formatting.

#### Note

Even if images are protected, these images will be deleted.

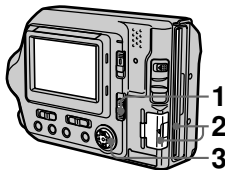

- 1 Select the floppy disk or the “Memory Stick” using the MS/FD selector.**
- 2 Insert only the floppy disk or the “Memory Stick” you want to format.**  
Be sure to insert only the media you want to format.
- 3 Select [FILE] from the menu.**
  - When formatting a floppy disk  
Select [DISK TOOL], [FORMAT], and then [OK] from the menu.
  - When formatting a “Memory Stick”  
Select [FORMAT], and then [OK] from the menu.

#### To cancel formatting

Select [CANCEL] in step 3.

## Notes

- Format the floppy disk or the “Memory Stick” only using this camera. You cannot format the floppy disk or the “Memory Stick” using a computer via the USB cable.
- When you format, be sure to use a fully charged battery pack or the AC power adaptor as the power source.

## ► As an external drive

### Using the camera as an external drive of a computer

Once you connect the camera to a computer using the USB cable, you can use the camera as a floppy disk/“Memory Stick” drive of a computer. Install the USB driver to the computer beforehand (pages 29, 35).

#### Example:

**For Windows 98, Windows 98SE, Windows 2000, Windows Me and Windows XP Users**

#### 1 Select the drive type using the MS/FD selector on this camera.

When used as the floppy disk drive, set the MS/FD selector to FD.

When used as the “Memory Stick” drive, set the MS/FD selector to MS.

#### 2 Connect the AC power adaptor and turn on the camera.

#### 3 Connect the camera to the computer using the supplied USB cable.

#### 4 Open “My Computer” on Windows and check the icon “Removable Disk,” then use the camera as an external drive.

#### Note

- When using Windows 2000, Windows Me, or Windows XP, see also page 31.
- The drive symbol ((D:), etc.) may differ depending on your computer.
- If you are using Mac OS X(v10.0/v10.1), you can use only a “Memory Stick” with a computer running Mac OS X(v10.0/v10.1). Even if you insert a floppy disk, Mac OS X(v10.0/v10.1) cannot recognize it. To use data saved on a floppy disk, copy it to a “Memory Stick” first (page 77).

## Additional information

### Precautions

#### On cleaning

##### Cleaning the LCD screen

Wipe the screen surface with a cleaning cloth (optional) or an LCD cleaning kit (optional) to remove fingerprints, dust, etc.

##### Cleaning the camera surface

Clean the camera surface with a soft cloth slightly moistened with water, then wipe the surface dry. Do not use any type of solvent such as thinner, alcohol or benzene as this may damage the finish or the casing.

##### After using your camera at the seashore or other dusty locations

Clean your camera carefully. Otherwise, the salty air may corrode the metal fittings or dust may enter the inside of your camera, causing a malfunction.

#### On floppy disks

To protect data recorded on floppy disks, note the following:

- Avoid storing floppy disks near magnets or magnetic fields such as those of speakers and televisions. Otherwise, permanent erasure of disk data may result.
- Avoid storing floppy disks in areas subject to direct sunlight or sources of high temperature, such as a heating device. Floppy disk warping or damage may result, rendering the disk useless.
- Avoid contact with the disk's surface by opening the disk shutter plate. If the disk's surface becomes blemished, data may be rendered unreadable.

- Avoid getting liquids on the floppy disk.
- Be sure to use a floppy disk case to ensure protection of important data.
- Even when you use a 3.5-inch 2HD floppy disk, image data may not be recorded and/or displayed depending on the using environment. In this case, use a disk of other brand.

#### On operating temperature

Your camera is designed for use between the temperatures of 0°C to 40°C (32°F to 104°F). Recording in extremely cold or hot places that exceed this range is not recommended.

#### On moisture condensation

If the camera is brought directly from a cold to a warm location, or is placed in a very damp room, moisture may condense inside or outside the camera. Should this occur, the camera will not operate properly.

##### Moisture condensation occurs easily when:

- The camera is brought from a cold location such as a ski slope into a warmly heated room.
- The camera is taken from an air-conditioned room or car interior to the hot outdoors, etc.

##### How to prevent moisture condensation

When bringing the camera from a cold place to a warm place, seal the camera in a plastic bag and allow it to adapt to conditions at the new location over a period of time (about an hour).

### **If moisture condensation occurs**

Immediately eject the floppy disk, then turn off the camera and wait about an hour for the moisture to evaporate. Note that if you attempt to record with moisture remaining inside the lens, you will be unable to record clear images.

### **On AC power adaptor**

- Unplug the unit from the wall outlet (wall socket) when you are not using the unit for a long time. To disconnect the power cord (mains lead), pull it out by the plug. Never pull the power cord (mains lead) itself.
- Do not operate the unit with a damaged cord (mains lead) or if the unit has been dropped or damaged.
- Do not bend the power cord (mains lead) forcibly, or place a heavy object on it. This will damage the cord (mains lead) and may cause fire or electrical shock.
- Prevent metallic objects from coming into contact with the metal parts of the connecting section. If this happens, a short may occur and the unit may be damaged.
- Always keep metal contacts clean.
- Do not disassemble the unit.
- Do not apply mechanical shock or drop the unit.
- While the unit is in use, particularly during charging, keep it away from AM receivers and video equipment. AM receivers and video equipment disturb AM reception and video operation.
- The unit becomes warm during use. This is not a malfunction.
- Do not place the unit in locations that are:
  - Extremely hot or cold
  - Dusty or dirty
  - Very humid
  - Vibrating

### **On battery pack**

- Use only the specified charger with the charging function.
- To prevent accident from a short circuit, do not allow metal objects to come into contact with the battery terminals.
- Keep the battery pack away from fire.
- Never expose the battery pack to temperatures above 60°C (140°F), such as in a car parked in the sun or under direct sunlight.
- Keep the battery pack dry.
- Do not expose the battery pack to any mechanical shock.
- Do not disassemble nor modify the battery pack.
- Attach the battery pack to the camera securely.
- Charging while some capacity remains does not affect the original battery capacity.

### **On the built-in rechargeable lithium battery**

Your camera is supplied with a built-in rechargeable lithium battery installed to retain the date/time and various settings, regardless of the setting of the POWER switch. The built-in rechargeable lithium battery is always charged as long as you are using your camera. The battery, however, will get discharged gradually if you do not use your camera. It will be completely discharged in about one month if you do not use your camera at all. Even if the built-in rechargeable lithium battery is not charged, it will not affect the camera operation. To retain the date and time, etc., charge the battery if the battery is discharged.

## Charging the built-in rechargeable lithium battery:

- Connect your camera to house current (mains) using the AC power adaptor supplied with your camera, and leave your camera with the power turned off for more than 24 hours.
- Or install the fully charged battery pack in your camera, and leave your camera with the power turned off for more than 24 hours.

If any problem occurs, unplug your camera and contact your nearest Sony dealer.



## On “Memory Stick”s

“Memory Stick” is a new compact, portable and versatile IC recording medium with a data capacity that exceeds a floppy disk. “Memory Stick” is specially designed for exchanging and sharing digital data among “Memory Stick” compatible products. Because it is removable, “Memory Stick” can also be used for external data storage.

There are two types of “Memory Stick”s: general “Memory Stick”s and “MagicGate Memory Stick”s that are equipped with the MagicGate\* copyright protection technology. You can use both types of “Memory Stick” with your camera. However, because your camera does not support the MagicGate standards, data recorded with your camera is not subject to MagicGate copyright protection.

\* MagicGate is copyright protection technology that uses encryption technology.

## Notes

- It is recommended that you make a backup copy of your important data.
  - Do not remove the “Memory Stick” while reading or writing data.
  - Data may be damaged if:
    - you remove the “Memory Stick” or turn off your camera while reading or writing data.
    - you use the “Memory Stick” in a location subject to the effects of static electricity or noise.
  - Do not attach any other material than the supplied label on the labeling position.
  - When you carry or store the “Memory Stick,” put it in its supplied case.
  - Do not touch the terminals of a “Memory Stick” with your hand or a metal object.
  - Do not strike, bend or drop the “Memory Stick.”
  - Do not disassemble or modify the “Memory Stick.”
  - Do not allow the “Memory Stick” to get wet.
  - Do not use or keep “Memory Stick”s in locations that are:
    - Extremely hot such as in a car parked in the sun or under the scorching sun.
    - Under direct sunlight.
    - Very humid or subject to corrosive gases.
- “Memory Stick”, , “MagicGate Memory Stick” and  are trademarks of Sony Corporation. “MagicGate” and **MAGICGATE** are trademarks of Sony Corporation.

## Using your camera abroad

### Power sources

You can use your camera in any country or area with the supplied battery charger within 100 V to 240 V AC, 50/60 Hz. Use a commercially available AC plug adaptor [a], if

necessary, depending on the design of the wall outlet (wall socket) [b].

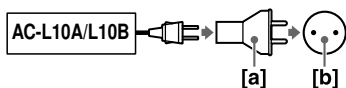

### Watching the playback picture on TV

If you want to view the playback picture on a TV, you need a TV having a video input jack and a video connecting cable.

The color system of the TV must be the same as that of your digital still camera. Check the following list:

#### NTSC system

Bahama Islands, Bolivia, Canada, Central America, Chile, Colombia, Ecuador, Guyana, Jamaica, Japan, Korea, Mexico, Peru, Surinam, Taiwan, the Philippines, the U.S.A., Venezuela, etc.

#### PAL system

Australia, Austria, Belgium, China, Czech Republic, Denmark, Finland, Germany, Holland, Hong Kong, Hungary, Italy, Kuwait, Malaysia, New Zealand, Norway, Poland, Portugal, Singapore, Slovak Republic, Spain, Sweden, Switzerland, Thailand, United Kingdom, etc.

#### PAL-M system

Brazil

#### PAL-N system

Argentina, Paraguay, Uruguay

#### SECAM system

Bulgaria, France, Guiana, Iran, Iraq, Monaco, Russia, Ukraine, etc.

## About “InfoLITHIUM” battery pack

### What is the “InfoLITHIUM” battery pack?

The “InfoLITHIUM” battery pack is a lithium-ion battery pack that has functions for communicating information related to operating conditions between your camera and the AC adaptor/charger (optional). The “InfoLITHIUM” battery pack calculates power consumption according to the operating conditions of your camera and displays the remaining battery time in minutes. If you use the AC adaptor/charger (optional), it will calculate and display the operation time and charging completion time also.

### Charging the battery pack

- Be sure to charge the battery pack before you start using your camera.
- We recommend charging the battery pack in an ambient temperature of between 10°C to 30°C (50°F to 86°F) until the POWER ON/OFF (CHG) lamp goes out, indicating that the battery pack is fully charged. If you charge the battery pack outside of this temperature range, you may not be able to efficiently charge the battery pack.
- After charging is completed, either disconnect the AC power adaptor from the DC IN jack on your camera or remove the battery pack.

### Effective use of the battery pack

- Battery performance decreases in low-temperature surroundings. So, the time that the battery pack can be used is shorter in cold places. We recommend the following to use the battery pack longer:
  - Put the battery pack in a pocket close to your body to warm it up, and insert it in your camera immediately before you start taking shots.
  - Use the large capacity battery pack (NP-F550, optional).
- Frequently using the LCD panel or frequently operating the zoom wears out the battery pack faster. We recommend using the large capacity battery pack (NP-F550, optional).
- Be certain to turn the POWER switch to off when not taking shots or playing back on your camera.
- Procure spare batteries that can last two or three times longer than the expected recording time. Also, make a trial recording before you record the actual images.
- Do not expose the battery pack to water. The battery pack is not water-resistant.

### Remaining battery time indicator

- If the power goes off although the battery remaining indicator indicates that the battery pack has enough power to operate, charge the battery pack fully again so that the indication on the battery remaining indicator is correct. Note, however, that the correct battery indication sometimes will not be restored if it is used in high temperatures for a long time or left in a fully charged state, or the battery pack is frequently used. Regard the remaining battery time indication as the approximate shooting time.

- The  mark indicating there is little remaining battery time sometimes flashes depending on the operating conditions or ambient temperature and environment even if the remaining battery time is 5 to 10 minutes.

### How to store the battery pack

- If the battery pack is not used for a long time, do the following procedure once per year to maintain proper function.
  1. Fully charge the battery.
  2. Discharge on your camera.
  3. Remove the battery from your camera and store it in a dry, cool place.
- To use the battery pack up on your camera, leave the POWER switch to on in PLAY mode until the power goes off without a floppy disk or a “Memory Stick” inserted.





### Battery life

- The battery life is limited. Battery capacity decreases little by little as you use it more and more, and as time passes. When the battery operating time is shortened considerably, a probable cause is that the battery pack has reached the end of its life. Please buy a new battery pack.
- The battery life varies according to how it is stored and operating conditions and environment for each battery pack.

## Troubleshooting

If you experience trouble with your camera, first check the following items. Should your camera still not operate properly after you have made these checks, consult your Sony dealer or local authorized Sony service facility. **If code displays (C:□□:□□) appear on the LCD screen, the self-diagnosis display function is working (page 95).**

Symptom	Cause and/or Solution
Your camera does not work.	<ul style="list-style-type: none"> <li>• You are not using an “InfoLITHIUM” battery pack. →Use an “InfoLITHIUM” battery pack (page 9).</li> <li>• The floppy disk is not inserted properly. →Eject the disk, and insert it again (page 16).</li> <li>• The battery level is too low. (The  indicator appears.) →Charge the battery pack fully (page 10).</li> <li>• The AC power adaptor is not connected securely. →Connect it securely to the DC IN jack and a wall outlet (wall socket) (pages 10, 13).</li> <li>• The malfunction occurs inside the camera. →Turn off the power, and turn on after one minute, then check that the camera works properly.</li> </ul>
Your camera cannot record images.	<ul style="list-style-type: none"> <li>• The PLAY/STILL/MOVIE selector is set to PLAY. →Set it to STILL or MOVIE (pages 18, 23).</li> <li>• No floppy disk is inserted into your camera. →Insert a floppy disk (page 16).</li> <li>• The tab on the disk is set to the unrecordable position. →Set it to the recording position (page 16).</li> <li>• No “Memory Stick” is inserted into your camera. →Insert a “Memory Stick” (page 17).</li> <li>• The write-protect switch on the “Memory Stick” is set to LOCK. →Set it to the recording position.</li> </ul>
The picture is out of focus.	<ul style="list-style-type: none"> <li>• Your camera is not in macro recording mode when you shoot a subject that is about 3 to 25 cm (1 3/16 to 9 7/8 inches) away from the lens. →Set the macro recording mode (page 64).</li> <li>→Move the zoom lever to the W side.</li> </ul>
The resizing function does not work.	<ul style="list-style-type: none"> <li>• You cannot resize moving images, text images, Clip Motion images, and uncompressed images.</li> </ul>

Symptom	Cause and/or Solution
You cannot display a print mark.	<ul style="list-style-type: none"> <li>You cannot display print marks on moving images, text images and Clip Motion images.</li> </ul>
The picture is noisy.	<ul style="list-style-type: none"> <li>Your camera is placed near a TV or other equipment that uses strong magnets. → Move your camera away from the TV, etc.</li> </ul>
The picture is too dark.	<ul style="list-style-type: none"> <li>You are shooting a subject with a light source behind the subject. → Adjust the exposure (page 67).</li> <li>The brightness of the LCD screen is too low. → Adjust the brightness of the LCD screen (page 20).</li> </ul>
The flash does not work.	<ul style="list-style-type: none"> <li>The flash is set to . → Set the flash to (no indication), , or  (page 22).</li> <li>The camera is in one of the following PROGRAM AE modes: Twilight, Twilight plus, or Landscape. → Cancel the PROGRAM AE function or set the flash to  (pages 22, 65).</li> <li>The PLAY/STILL/MOVIE selector is set to MOVIE. → Set it to STILL.</li> </ul>
The date and time are recorded incorrectly.	<ul style="list-style-type: none"> <li>The date and time are not set correctly. → Set the correct date and time (page 14).</li> </ul>
Vertical streaks appear when you are shooting a very bright subject.	<ul style="list-style-type: none"> <li>This is called the smear phenomenon. → This is not a malfunction.</li> </ul>
The zoom does not work.	<ul style="list-style-type: none"> <li>PROGRAM AE is set to the Panfocus mode. → Cancel the Panfocus mode (page 65).</li> </ul>
Digital zoom does not work.	<ul style="list-style-type: none"> <li>You cannot use digital zoom when recording moving pictures.</li> <li>Digital zoom is set to [OFF]. → Set digital zoom to [ON] at the menu.</li> </ul>
The image is in monochrome.	<ul style="list-style-type: none"> <li>You shot the image in TEXT mode. → Cancel the TEXT mode (page 62).</li> <li>The picture effect is set to B&amp;W. → Cancel the B&amp;W mode (page 69).</li> </ul>
The image cannot be played back on a computer.	<ul style="list-style-type: none"> <li>→ Consult the computer or software manufacturer.</li> </ul>

Symptom	Cause and/or Solution
The moving image breaks off when you play back an image on a computer.	<ul style="list-style-type: none"> <li>• You are playing back the file from the floppy disk or the “Memory Stick.”</li> <li>→ Copy the file to the hard disk of the computer and then play back the file from the hard disk (page 32).</li> </ul>
Your camera cannot delete an image.	<ul style="list-style-type: none"> <li>• The image is protected.</li> <li>→ Cancel the protection (page 74).</li> </ul>
The power turns off suddenly.	<ul style="list-style-type: none"> <li>• With the PLAY/STILL/MOVIE selector set to STILL or MOVIE, if you do not operate the camera for about three minutes while the power is on, the camera turns off automatically to prevent wearing down the battery pack.</li> <li>→ Turn on the camera.</li> <li>• The battery pack is discharged.</li> <li>→ Replace it with a fully charged battery pack.</li> </ul>
The image does not appear on the TV screen.	<ul style="list-style-type: none"> <li>• The VIDEO OUT setting of your camera is incorrect.</li> <li>→ Change the setting (page 55).</li> </ul>
The slide show function stops automatically.	<ul style="list-style-type: none"> <li>• The slide show function stops after about 20 minutes when using a floppy disk.</li> <li>→ To continue the slide show, select [START] again (page 72).</li> </ul>
You cannot use the PROGRAM AE function.	<ul style="list-style-type: none"> <li>• Your camera is set to TEXT mode or the PLAY/STILL/MOVIE selector is set to MOVIE.</li> <li>→ Set the PLAY/STILL/MOVIE selector to STILL and change the setting (pages 53, 54).</li> </ul>
The macro function does not work.	<ul style="list-style-type: none"> <li>• PROGRAM AE is set to the Panfocus mode.</li> <li>→ Cancel the Panfocus mode (page 65).</li> </ul>

Symptom	Cause and/or Solution
Your computer does not recognize your camera.	<ul style="list-style-type: none"> <li>• The battery level is low. → Use the AC power adaptor (page 13).</li> <li>• The camera is turned off. → Turn on the camera.</li> <li>• The USB cable is not connected firmly. → Disconnect the USB cable, and connect it again firmly. Make sure that “USB MODE” is displayed on the LCD screen (page 30).</li> <li>• The USB connectors on your computer are connected to other equipment besides the keyboard, the mouse, and your camera. → Disconnect the USB cables except for the ones connected to the keyboard, the mouse, and your camera.</li> <li>• The position of the MS/FD selector is not set to the proper position for the media being used. → Set the MS/FD selector to the proper position.</li> <li>• The USB driver is not installed. → Install the USB driver (page 29).</li> <li>• <b>For Windows 98, Windows 98SE, Windows 2000 and Windows Me users</b> Since the camera is connected to a computer using the USB cable before installing the USB driver, the drive is not recognized properly by the computer. → Delete the drive which is not recognized properly, then install the USB driver. For details, see the procedure on page 33.</li> </ul>

## Battery packs



Symptom	Cause and/or Solution
The battery pack cannot be charged.	<ul style="list-style-type: none"> <li>• The power of the camera is turned on. → Turn off the power of the camera (page 10).</li> </ul>
The battery life is short.	<ul style="list-style-type: none"> <li>• You are recording/playing back images under extremely cold temperatures.</li> <li>• The battery pack is not charged enough. → Charge the battery pack fully.</li> <li>• The battery pack is dead. → Replace the battery pack with a new one.</li> </ul>

Symptom	Cause and/or Solution
<p>The indication of the battery remaining time is not proper, or the power is immediately turned off even if the battery remaining indicator indicates that the battery level is sufficient.</p>	<ul style="list-style-type: none"> <li>• You are using the camera for many hours under extremely hot or cold temperatures.</li> <li>• The battery pack is dead.               <ul style="list-style-type: none"> <li>→ Replace the battery pack with a new one (page 9).</li> </ul> </li> <li>• The battery level is too low.               <ul style="list-style-type: none"> <li>→ Install the fully charged battery pack (pages 9, 10).</li> </ul> </li> <li>• A deviation has occurred in the remaining battery time.               <ul style="list-style-type: none"> <li>→ Charge the battery pack fully (page 10).</li> </ul> </li> </ul>
<p>The POWER ON/OFF (CHG) lamp flashes when charging a battery pack.</p>	<ul style="list-style-type: none"> <li>• A malfunction has occurred in the battery pack.               <ul style="list-style-type: none"> <li>→ Contact your Sony dealer or local authorized Sony service facility.</li> </ul> </li> </ul>
<p>The POWER ON/OFF (CHG) lamp does not light up when charging a battery pack.</p>	<ul style="list-style-type: none"> <li>• The AC power adaptor is not connected.               <ul style="list-style-type: none"> <li>→ Connect the power cord firmly to a wall outlet (wall socket) (page 10).</li> </ul> </li> <li>• The battery pack is not installed properly.               <ul style="list-style-type: none"> <li>→ Install it properly (page 9).</li> </ul> </li> <li>• Charging of the battery pack is complete.</li> </ul>

## Warning and notice messages

Various messages appear on the LCD screen. Check the corresponding descriptions in the following list.

Message	Meaning
DRIVE ERROR	There is trouble with the disk drive.
SYSTEM ERROR	Turn the power off and on again.
NO DISK	No disk is inserted.
NO MEMORY STICK	No "Memory Stick" is inserted.
FORMAT ERROR	<ul style="list-style-type: none"><li>• The floppy disk loaded is not MS-DOS formatted (512 bytes × 18 sectors).</li><li>• Failed to format the "Memory Stick."</li><li>• The Floppy Disk Adaptor for Memory Stick is inserted.</li></ul>
MEMORY STICK ERROR	The inserted "Memory Stick" cannot be used with your camera, or the "Memory Stick" is damaged or not inserted correctly.
DISK PROTECT	The tab on the disk is set to the unrecordable position.
MEMORY STICK LOCKED	The write-protect switch on the "Memory Stick" is set to the LOCK position.
DISK FULL	The disk is full.
NO MEMORY SPACE	The capacity of the "Memory Stick" is not sufficient to record images.
NO FILE	No image is recorded in a floppy disk or a "Memory Stick."
FILE ERROR	Trouble has occurred during playback.
FILE PROTECT	The image is protected.
DISK ERROR	A 2DD floppy disk is inserted, or there is trouble with the disk.
DIRECTORY ERROR	A directory with the same name already exists.
NOT ENOUGH MEMORY	The remaining capacity of the floppy disk or the "Memory Stick" is not enough to copy the image.

Message	Meaning
IMAGE SIZE OVER	You tried to play back images with an image size larger than the maximum playback size of this camera.
INVALID OPERATION	You are playing back a file that was created on equipment other than your camera.
for “InfoLITHIUM” battery only	The battery is not the “InfoLITHIUM” type.
	The image is protected.
	The battery level is too low. When the remaining time is about 5 to 10 minutes,  may flash depending on the battery pack used, operating conditions, or the environment.

## Self-diagnosis display

Your camera has a self-diagnosis display. This function displays the camera condition on the LCD screen with a combination of a letter and four digits of numbers. If this appears, check the following code chart. The code informs you of the camera's current condition. The last two digits (indicated by □□) will differ depending on the state of the camera.



### Self-diagnosis display

- C: □□: □□

You can correct the problem by yourself.

- E: □□: □□

Contact your Sony dealer or local authorized Sony service facility.

Code	Cause and/or Corrective Action
C:32:□□	<ul style="list-style-type: none"><li>• There is trouble with the disk drive. → Turn the power off and on again.</li></ul>
C:13:□□	<ul style="list-style-type: none"><li>• An unformatted floppy disk or "Memory Stick" is inserted. → Format the floppy disk or the "Memory Stick." (page 81)</li><li>• A floppy disk or a "Memory Stick" not compatible with this camera is inserted. → Change the floppy disk or the "Memory Stick." (pages 16, 17)</li></ul>
E:61:□□ E:91:□□	<ul style="list-style-type: none"><li>• A camera malfunction that you cannot repair has occurred. → Contact your Sony dealer or local authorized Sony service facility and inform them of the 5-digit indication. (example: E:61:10)</li></ul>

**If you are unable to rectify the problem even if you try corrective actions a few times when C:□□:□□ is indicated, contact your Sony dealer or local authorized Sony service facility.**

# Specifications

## System

### Image device

6.64 mm (1/2.7 type)

Color CCD

### Effective pixels number of camera

MVC-FD100:

Approx. 1 228 000 pixels

MVC-FD200:

Approx. 1 976 000 pixels

### Lens

3× zoom lens

f = 6.4 – 19.2 mm (9/32 – 25/32 inches)

(41 – 123 mm

(1 5/8 – 4 7/8 inches) when converted into a 35 mm still camera)

F = 3.8 – 3.9

### Exposure control

Automatic exposure

### White balance

Automatic, Indoor, Outdoor, Hold

### Data system

Movie: MPEG

Still: JPEG, GIF (in TEXT mode, Clip Motion), TIFF  
MPEG

### Recording medium

Floppy disk:

3.5-inch 2HD MS-DOS format (1.44 MB)

“Memory Stick”

### Flash

Recommended recording distance (ISO set to AUTO):

0.5 m to 2.0 m (1 2/3 feet to 6 2/3 feet)

## Input and Output connector

### VIDEO OUT

Minijack

Video: 1 Vp-p, 75 Ω  
unbalanced, sync negative

### USB jack

mini-B

## LCD screen

### LCD panel

6.2 cm (2.5 type)

TFT (Thin Film Transistor active matrix) drive

### Total number of dots

123 200 (560×220) dots

## General

### Application

Sony battery pack NP-F330 (supplied)/F550 (Optional)

### Power requirements

7.2 V

### Power consumption (During shooting and LCD backlight is on)

MVC-FD100: 3.5 W

MVC-FD200: 3.6 W

### Operating temperature

0°C to 40°C (32°F to 104°F)

### Storage temperature

–20°C to +60°C (–4°F to +140°F)

### Dimensions (Approx.)

142 × 104 × 77 mm (5 1/2 × 4 × 3 inches) (w/h/d)

### Mass (Approx.)

645 g (1 lb 7 oz)  
(including NP-F330 battery pack, floppy disk and lens cap, etc.)

## AC-L10A/L10B

### AC power adaptor

#### Power requirements

100 to 240 V AC, 50/60 Hz

#### Rated output voltage

DC 8.4 V, 1.5 A in operating mode

#### Operating temperature

0°C to 40°C (32°F to 104°F)

#### Storage temperature

–20°C to +60°C (–4°F to +140°F)

## Dimensions (Approx.)

125×39×62 mm (5×1 9/16× 2 1/2 inches) (w/h/d)

## Mass (Approx.)

280 g (10 oz)

## NP-F330 battery pack

### Battery type

Lithium ion

### Maximum output voltage

DC 8.4 V

### Mean output voltage

DC 7.2 V

### Capacity

5.0 Wh (700 mAh)

### Operating temperature

0°C to 40°C (32°F to 104°F)

### Dimensions (Approx.)

38.4×20.6×70.8 mm  
(1 9/16×13/16×2 7/8 inches) (w/h/d)

### Mass (Approx.)

70 g (2 oz)

## Accessories

AC-L10A/L10B

AC power adaptor (1)

Power cord (mains lead) (1)

USB cable (1)

NP-F330 battery pack (1)

VIDEO connecting cable (1)

Shoulder strap (1)

Lens cap (1)

Lens cap strap (1)

CD-ROM (SPVD-008 USB Driver) (1)

Operating instructions (1)

Design and specifications are subject to change without notice.

## LCD screen indicators

### The indicators during recording

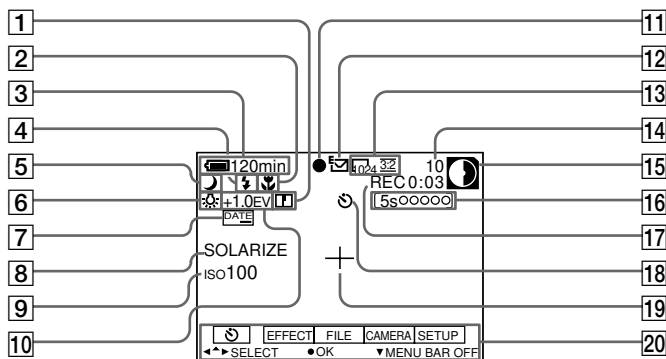

- 1 Sharpness indicator
- 2 Focus mode indicator/Macro indicator
- 3 Battery remaining indicator
- 4 Flash level indicator/Flash mode indicator
- 5 PROGRAM AE indicator/Zoom indicator
- 6 White balance indicator
- 7 DATE/TIME indicator
- 8 Picture effect indicator
- 9 ISO film speed indicator
- 10 EV level indicator
- 11 AE/AF lock indicator
- 12 Recording mode/Clip Motion indicator
- 13 Image size indicator
- 14 Number of recorded images
- 15 Remaining disk capacity/  
Remaining memory capacity  
indicator  
☾: Floppy disk  
📁: "Memory Stick"
- 16 Recording time indicator
- 17 Self-diagnosis function  
indicator/Recording time  
indicator
- 18 Self-timer indicator
- 19 Spot light-metering indicator
- 20 Menu bar and guide menu  
They appear by pressing ▲ on the  
control button and disappear by  
pressing ▼.

## The indicators during still image playback

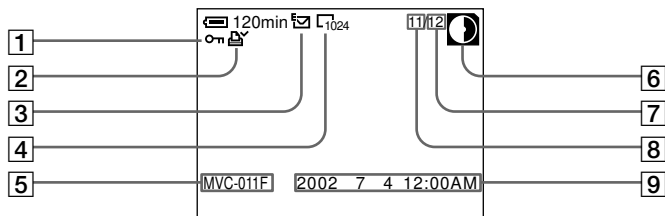

- 1 Protect indicator/Zoom scaling indicator
- 2 Print mark indicator
- 3 Recording mode/Clip Motion indicator
- 4 Image size indicator
- 5 File name\*
- 6 Remaining disk capacity/  
Remaining memory capacity indicator

- 7 Number of stored images on a floppy disk or a "Memory Stick"
- 8 Image number
- 9 Recording date of the playback image\*

\* When the menu bar is displayed, this indicator disappears from the screen.

## The indicators during moving image playback

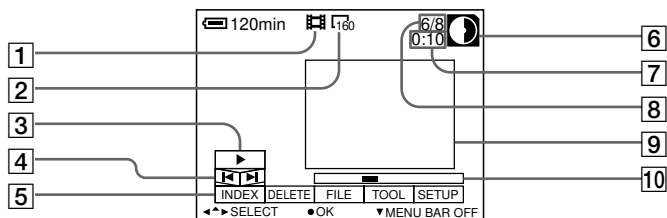

- 1 Moving image file indicator
- 2 Image size indicator
- 3 Playback button/pause button  
▶ is displayed during stop, and || during playback.
- 4 Image searching buttons
- 5 Menu bar and guide menu

- 6 Remaining disk capacity/  
Remaining memory capacity indicator
- 7 Counter
- 8 Image number/number of stored images on a floppy disk or a "Memory Stick"
- 9 Playback image
- 10 Playback bar

# Index

## A

- AC power adaptor..... 10, 13
- Adjusting brightness
  - Image..... 67
  - LCD screen..... 20
- Auto power-off function.. 11

## B

- Battery pack
  - Charging..... 10
  - Installing..... 9
  - Remaining time..... 10
  - Usable time..... 11
- BEEP..... 56

## C

- Charging..... 10
- Cleaning..... 83
- Clip Motion..... 59
- CLOCK SET..... 14
- Control button..... 48
- COPY..... 77

## D

- DELETE..... 75
- DEMO..... 55
- DIGITAL ZOOM..... 21, 54
- DISK COPY..... 79
- DISK TOOL..... 51
- DPOF..... 80

## E

- Editing
  - COPY..... 77
  - DELETE..... 75
  - PROTECT..... 74
- E-MAIL..... 61
- EXPOSURE..... 67

## F

- FILE NUMBER..... 52
- FLASH LEVEL..... 54
- Floppy disk
  - Copying..... 79
  - Format..... 81
  - Inserting..... 16
  - Number of recordable images
    - ..... 58, 60, 61, 62, 63
    - Usable type..... 16
- FORMAT..... 81
- Full charge..... 10

## G

- GIF..... 27, 41, 59, 62

## I

- Image
  - Copying..... 77
  - Deleting..... 75
  - File name..... 38
  - Print mark..... 80
  - Protect..... 74
  - Size..... 57
- INDEX screen..... 70
- Indicators on the LCD screen..... 97
- "InfoLITHIUM" battery pack..... 9, 86
- ISO film speed..... 54, 65

## J

- JPEG..... 18, 27, 41

## M

- Macro recording..... 64
- Manual focusing..... 64
- "Memory Stick"
  - Copying..... 77
  - Format..... 81
  - Inserting..... 17
  - Number of recordable images
    - ..... 58, 60, 61, 62, 63
- Menu..... 50
- MOBILE mode..... 59
- Moisture condensation..... 83
- Moving image
  - Playback..... 25
  - Recording..... 23
- MPEG..... 23, 27

## N

- Number of recordable images
  - Battery pack..... 11
  - Clip Motion..... 60
  - E-mail mode..... 61
  - Image size..... 58
  - TEXT mode..... 62
  - TIFF mode..... 63

## P

- PICTURE EFFECT..... 69
- PLAY/STILL/MOVIE selector..... 48
- Playing back
  - INDEX screen..... 70
  - Moving images..... 25
  - Slide show..... 72
  - Still images..... 24
  - Viewing images on a TV screen..... 73
- Viewing images using a computer..... 27

- Power source
  - AC power adaptor..... 13
  - Battery pack..... 9
- PRINT MARK..... 80
- PROGRAM AE..... 65
- PROTECT..... 74

## R

- REC MODE..... 53
- Recording
  - Clip Motion..... 59
  - E-mail mode..... 61
  - In macro..... 64
  - Moving image..... 23
  - Still image..... 18
  - TEXT mode..... 62
  - TIFF mode..... 63
  - With flash..... 22
- RESIZE..... 76

## S

- Self timer..... 21
- Self-diagnosis display..... 95
- Setting the date and time.. 14
- SHARPNESS..... 54
- Single display..... 70
- SLIDE SHOW..... 72
- Still image
  - Playback..... 24
  - Recording..... 18

## T

- TEXT mode..... 62
- TIFF..... 63

## U

- USB..... 27
- Using flash..... 22
- Using your camera abroad..... 85

## V

- Viewing images using a computer..... 27

## W

- Warning messages..... 93
- WHITE BALANCE..... 68

## Z

- Zoom..... 20



Printed on 100% recycled paper using  
VOC (Volatile Organic Compound)-free  
vegetable oil based ink.

<http://www.sony.net/>

Sony Corporation Printed in Japan



3 0 7 3 0 7 4 1 3